



User's Manual

DU6871
DX6851
DW6831

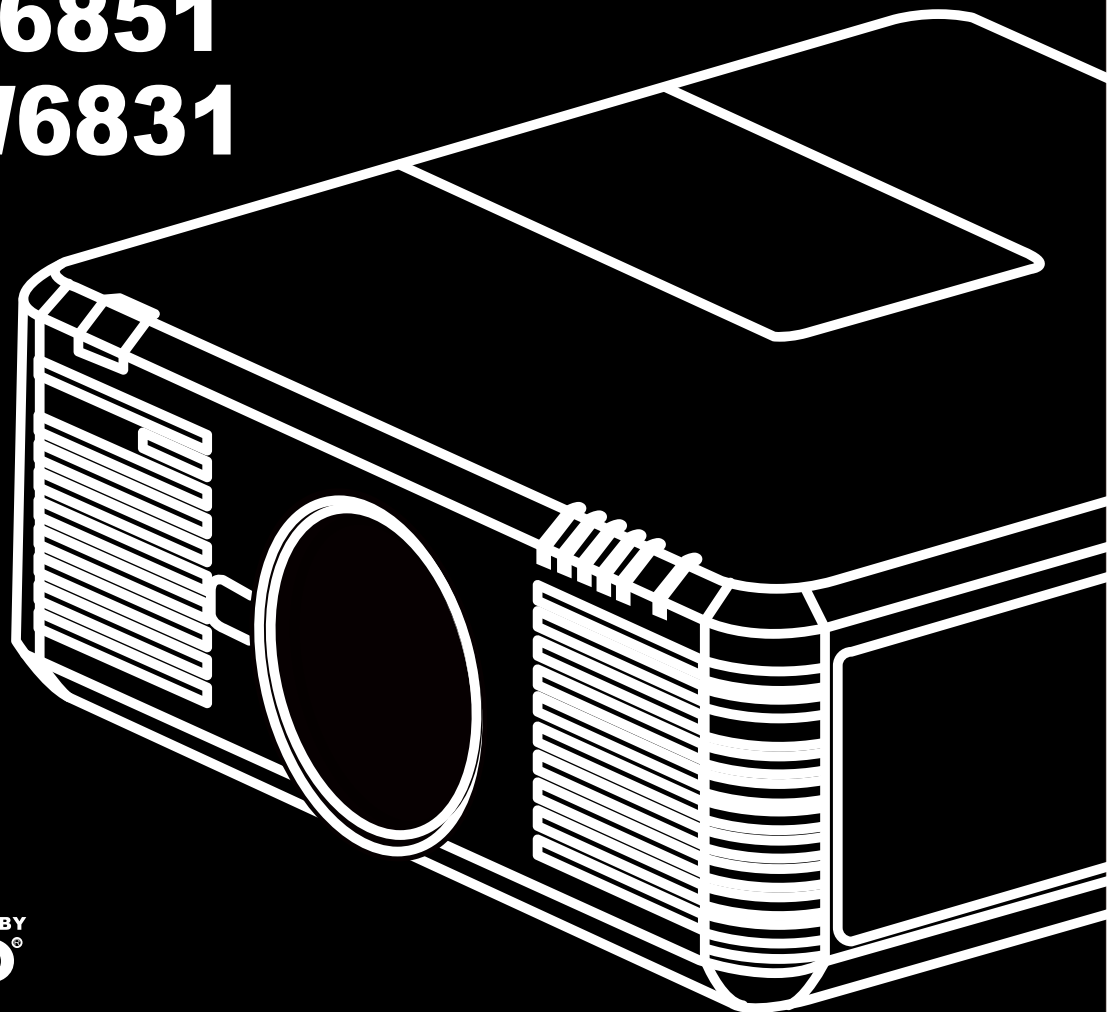

Table of Contents

Copyright	4
Copyright	4
Disclaimer	4
About the Manual	4
Important Safety Guidelines	5
Installation and Use Notice	5
Disposal of Old Electric and Electronic Equipment	6
Important Recycling Instructions	6
Introduction	7
Product Features	7
Packing Checklist	8
Projector Overview	9
I/O Panel	10
Control Panel	11
Remote Control	12
Installation of the Remote Control Battery	13
Remote Control Operating Range	13
Precautions For installation	14
Projector Installation and Setup	14
Cautions on ventilation	15
Lens Shift	16
Connecting the Projector to Other Equipment	17
Connecting to the personal computer	17
Connecting to the video equipment	17
Connecting to the control equipment	18
Connecting to the Screen Trigger	19
Connecting to the External HDBaseT Transmitter	20
Starting to Use the Projector Setup	21
Connecting to AC Power Supply	21
Turn on	21
Changing the OSD Language	22
Adjusting the projection mode	22
Lens Shift	23
Starting to Use the Projector-Operation	24
Use OSD	24
OSD Menu Tree	25
OSD Menu - INPUT	29
OSD Menu - PICTURE	31
OSD Menu - LAMP	33
OSD Menu - ALIGNMENT	35
OSD Menu - CONTROL	39
OSD Menu - SERVICE	43

Replacing the Lamps	44
Installing or Removing the Projection lens	45
Replacing the filter	46
Changing the Color Wheel	47
LED indicator status	48
Power LED indicator	48
Status LED indicator	48
Lamp 1/Lamp 2 LED indicator	48
Temperature LED indicator	48
Shutter LED indicator	48
DU6871/DW6851/DX6831 specifications	49
Outline Dimensions	50
Supported Signal Input Timing	51
Computer	51
3D Signal Input Mode	52
DU6871/DW6851/DX6831 lens series	53
About the VIVITEK support	54

Copyright

Copyright

The User's Manual (including all pictures, illustrations and software) is protected by the international copyright right law. All rights are reserved.

No duplication of the manual or any content included in the manual is allowed without the written consent of the manufacturer.

Vivitek is the trademark of Vivitek Corporation. ©All rights reserved. 2014

Disclaimer

The information in the manual is subject to change without notice.

The manufacturer does not provide any statement or warranty of the contents in the manual and clearly give up the implied warranties of merchantability and of fitness for a particular purpose. The manufacturer reserves the rights to modify the publication and change the contents of the materials at any time without notice to any person.

About the Manual



The manual describes how to install and use the DLP projector and is applicable to the end-user. Relevant information (such as illustrations and descriptions) is put on the same page as possible as we can. The format, easy for printing, is convenient for reading and paper-saving which is beneficial to environmental protection. It is suggested printing the page you need.

Important Safety Guidelines

Thank you for purchasing the high quality product!

Read the Manual carefully to obtain the best performance. The Manual provides instructions to use the menu and implement operation.

Installation and Use Notice

1. Read and keep the description properly.
2. Pay attention to all warnings.
3. Follow all guidelines and descriptions.
4. Do not use the equipment near water. Do not install the equipment near the thermal source, such as the heater, radiator, furnace or other equipment that will generate heat (including the amplifier).
5. Use dry clothes to clean only.
6. Do not obstruct any vent. Carry out installation according to the guidelines of the Manufacturer.
7. Do not destroy the safety protection function of polarized or grounding plugs. A polarized plug has one wide and one narrow blade. The grounding plug has two blades and one grounding blade. The wide blade or grounding blade is provided for the safety concerns. If the plug provided does not match the outlet, contact the electrician to change the old outlet.
8. Prevent the power cord from being treaded or pressed, especially the power cord on the plug, outlet and the connection between the power cord and the equipment.
9. Only use the connectors/accessories designated by the Manufacturer.
10. Be careful of moving the trolley/equipment and avoid being hurt due to turning-over when using the trolley. 
11. Unplug the power cord of the equipment if there is a thunderstorm or the equipment will not be used for a long time.
12. The authorized maintenance personnel is responsible for all maintenance work. The equipment should be repaired if damaged in any means. (For example, the power cord or outlet is damaged. Liquids splash to the equipment or foreign objects fall into the equipment. The equipment is exposed to rain or humidity. The equipment cannot work functionally or falls.)
13. The +12V trigger only outputs 12V DC trigger signal. Do not connect to other power input or output. Otherwise, the equipment may be damaged.
14. The packaging materials should be kept properly for the use of transportation.
15. Do not look straight at the lens when the projector is running. 
16. The product can be used safely below the elevation of 2000m. There may be safety risk if the product is used above the elevation of 2000m.

Disposal of Old Electric and Electronic Equipment

The symbol on your product or the package represents that the product should not be treated as the normal household waste when discarded but should be carried to the recycling location of the waste electric and electronic equipment. The consequence on the environment and human health due to the incorrect disposal of the product can be prevented if it can be ensured that the product is properly discarded. Material recycling is helpful to the protection of natural resources. The symbol is only valid in European Union. If you want to discard electrical and electronic equipment, contact the governmental authorities or your dealer for the correct method of disposal. 

Important Recycling Instructions

The lamp of the product contains mercury. The product may contain other electronic wastes and may pose risk if not discarded properly. Abide by the local, state/provincial or federal laws of recycling or discarding.

For more information, please visit the website and contact Electronic Industries Alliance (EIA) on WWW.EIAE.ORG.

Please visit WWW.LAMPRECYCLE.ORG for the specific disposal information of lamps. (Hg)

Introduction

The User's Manual describes the installation, setup and operation of the DU6871/DW6851/DX6831 projector and provides assistance to the installation personnel and the end-user to fully develop the performance of the projector. VIVITEK has made every efforts to ensure that the information in the Manual is correct at the time of printing. The contents may be frequently updated due to the continuously product improvement and customer feedback. You can find the latest version of the Manual and the manual of other Vivitek products on www.vivitekcorp.com.

Product Features

VivitekDU6871/DW6851/DX6831 has the cutting-edge technique and creative dual-lamp optical engine to provide the native high resolution as well as clear, brilliant and vivid pictures. Main Characteristics and Advantages of the Product Series

- The DLP system with the high performance digital micromirror device (DMD) in conjunction with the advanced thermal management technology provide the excellent projecting performance and reliability.
- The advanced dual-lamp optical engine as well as the single-lamp, dual-lamp, normal, energy-saving and Custom Lamp Power mode offer the convenience for installation. The power of lamps can be adjusted in the normal and energy-saving modes to make it easier for the installation personnel to fine-tune the edge blending brightness of multiple projectors.
- With the lamp switching feature, the projector can automatically select the lamps less used when turned on.
- The projector has the replaceable color wheel and smart color wheel switch design, can automatically detect and switch the parameter of corresponding color wheels and can be used in conjunction with the color wheel of high brightness or beautiful hues. It is applicable to the single projector.
- The interchangeable lens design allows the user to easily and quickly change the suitable lens by pressing the Lens Release key.
- With the complete series of motorized projection lenses, the horizontal shift, focusing and zooming of lenses can be electrically controlled. The throw ratio ranges from 0.7:1 to 8.5:1 and is suitable to be used in most applications.
- With the built-in Lens Memory feature, lens homing can be automatically implemented. 10 sets of lens shift, focusing and zooming can be saved at most. The setup and quick adjustment can be carried out.
- The mechanical shutter is built in the optical engine and allows the user to turn on/pause projection by pressing a single key.
- The high performance video processor can be used in progressive and interlaced scanning of the video inputs and video denoising.
- The complete input terminal support many input signals, such as HDMI, DisplayPort, HDBaseT, YPbPr and VGA, etc.
- With the built-in HDBaseT signal reception, HDBaseT transmitter can send high quality video and control signals through the single RJ45 cable.
- Many 3D display format is supported, such as Frame Sequential, Top/Bottom, Side by Side and Frame Packing.
- The synchronization of DLP Link and 3D IR is supported.
- With the high efficient power switch, the power consumption less than 0.5W in the stand-by mode.

Packing Checklist

The following items are included in the packaging box of the DU6871/DW6851/DX6831 projector. If any loss or damage to any item, contact your dealer or the VIVITEK customer service department.

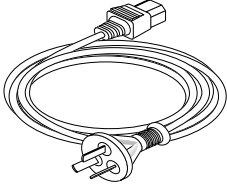

AC power cord

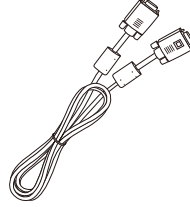

VGA signal cable

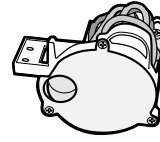

Color-optimized color wheel



IR remote control

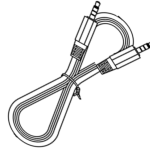

Cable of the wired remote control

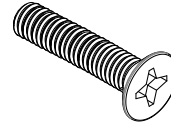

M4 screw

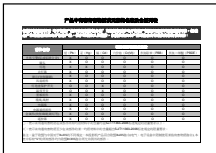

RoHS card (China)



User's Manual disc



Qualification certificate (China)

Projector Overview

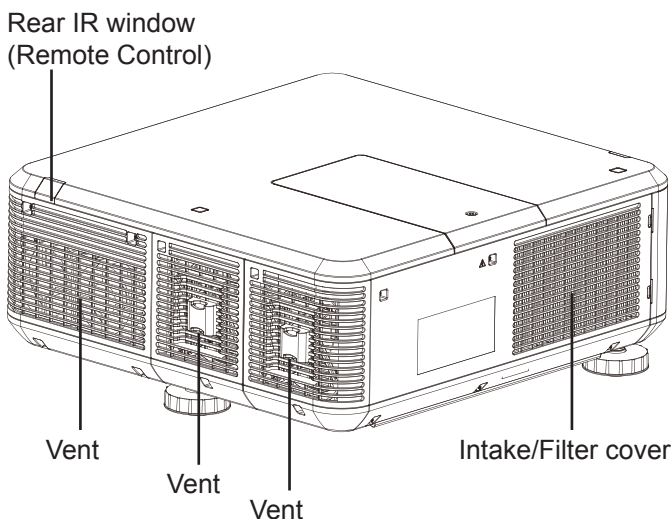
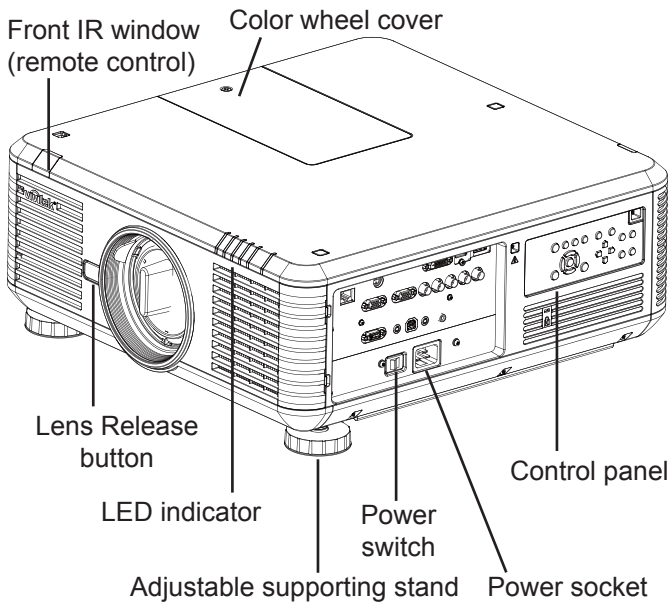

- **Vent**
Heat is discharged from the projector via the vent. Make sure that the vent is clear.
- **Intake/Filter cover**
The internal fan pulls cool air to the projector via the intake.
- **Adjustable supporting stand**
When the projector is installed on a desk, these stands can be used to adjust the levelness the projection angle.
- **Power socket**
The power from the outlet on the wall is directed to the projector.
- **Power switch**
The switch is used to turn on or off AC power of the projector.
- **Control panel**
The user can use the buttons to select and adjust the settings of the projector.
- **LED indicator**
It shows the status of the projector.
- **Lens Release button**
The user can push the Lens Release button to change the selected projector lens.
- **Lens burglarproof screw**
The burglarproof screw can be fasten to prevent easy removal of the projector lens.
Note: The user cannot remove the lens by pressing the Lens Release button if the lens burglarproof screw is fastened. Make sure the burglarproof screw is unfastened if the lens is to be removed.
- **Color wheel cover**
The projector supports automatic switch of the color wheel settings. The color wheel cover can be lifted to change the selected color wheel after the projector is turned off. The projector will automatically switch to the corresponding color wheel settings after turned on.
- **IR window**
The control signal from the remote control can be received via the window.

I/O Panel

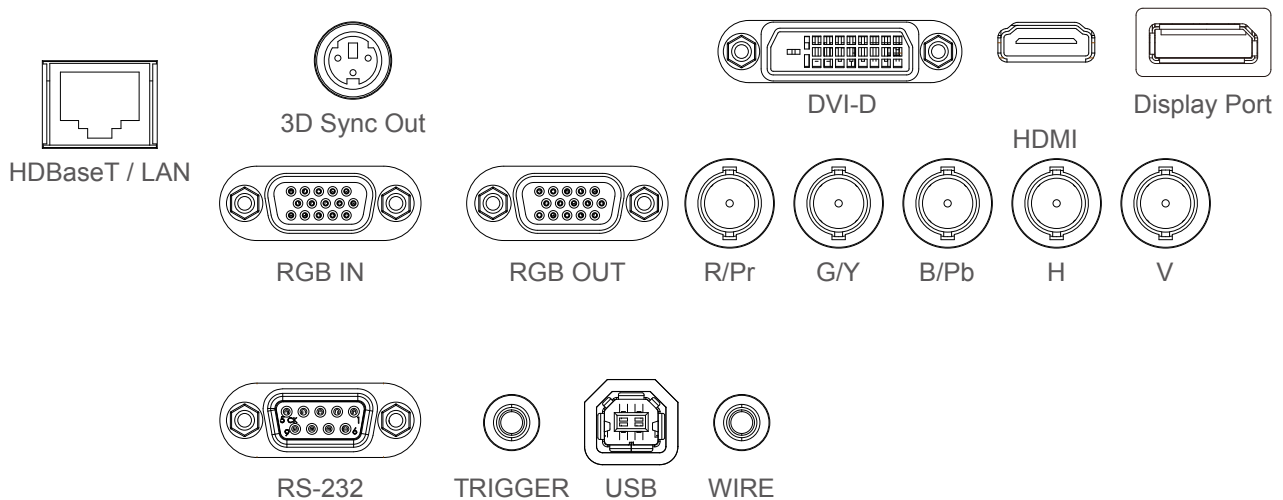

- **HDBaseT/LAN**
Connect to the RJ45 Cat5/Cat6 Ethernet cable.
- **3D Sync Out**
Connect to the 3D IR synchronization signal transmitter.
- **DVI**
Connect to DVI source.
- **HDMI**
Connect to HDMI source.
- **DisplayPort**
Connect to the equipment with DisplayPort or personnel computer.
- **RGB In**
Provide the standard 15-pin VGA connection and can connect to RGB, HD Component or personal computer.
- **RGB Out**
Connect to other display equipment to show the contents played simultaneously.
- **R/Pr, G/Y, B/Pb, H, V**
Connect BNC-type input terminal to the RGB or YPbPr/YCbCr output signal of video equipment.
- **RS-232**
The 9-pin D-sub interface is used to connect to the PC control system and projector maintenance.
- **TRIGGER (Trigger)**
The 3.5mm mini earphone jack provides 12V (+/-1.5) output for screen control.
- **USB**
It is a port exclusively used for maintenance and only can be used by the authorized maintenance personnel.
- **WIRE (wired remote control)**
Connect to the input from the compatible IR transponder system of Niles or Xantech to become the wired remote control.

Note: Please make sure whether the port for insertion is correct before the terminal of the wired remote control is inserted. The remote control may be damaged if inserted to the wrong port such as trigger.

Control Panel

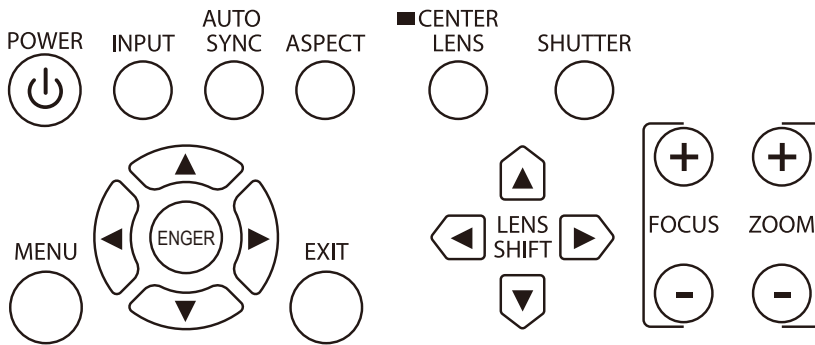

- **POWER**
Use the button to turn on/off the projector.
- **INPUT**
Push the button to select the video source. HDMI, DVI, VGA, Component/BNC DisplayPort or HDBaseT.
- **AUTO SYNC**
Implement automatic signal synchronization.
- **ASPECT**
Change the aspect ratio of the current image and push the button to change to the next aspect ratio settings.
- **MENU**
Push the button to display or hide the OSD menu.
- **ENTER**
Use the button to select settings or confirm the changed settings.
- **EXIT**
Push the button to return to the menu on the previous level or exit the OSD menu.
- **CENTER LENS**
Push the button to center the lens and calibrate the parameter of lens shift, focusing and zooming.
Note: The lens memory function requires the accurate lens adjustment parameter. Please center the lens every time after the lens is mounted.
- **SHUTTER**
Use the button to open/close the shutter.
- **LENS SHIFT**
Use the button to move the lens to the right or left.
- **FOCUS**
Use the button to adjust the focus of projected image.
- **ZOOM**
Use the button to zoom in/out the lens.

Remote Control

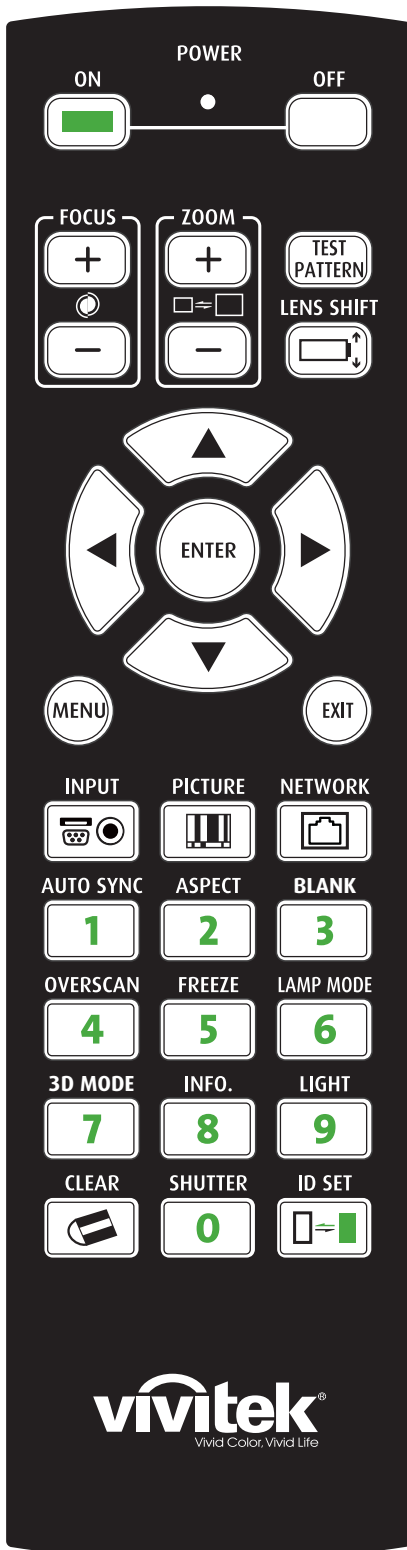

- **ON**
Use the button to turn on the projector.
- **OFF**
Use the button to turn off the projector.
- **FOCUS**
Adjust the focus of the projected image.
- **ZOOM**
Zoom in/out the projected image.
- **TEST PATTERN**
Use the button to display the test image. Push to switch to the next test image and push the **EXIT** button to return to the projected image.
- **LENS SHIFT**
Use the button to move the lens to the right or left.
- **ENTER**
Use the button to select settings or confirm the changed settings.
- **MENU**
Push the button to display or hide the OSD menu.
- **EXIT**
Push the button to return to the menu on the previous level or exit the OSD menu.
- **INPUT**
Push the button to select the input source.
- **PICTURE**
Start to adjust the image.
- **NETWORK**
Push the button to enter the LAN menu.
- **AUTO SYNC**
Push the button to carry out automatic signal synchronization.
- **ASPECT**
Repeatedly push the button to select the proportion for the next screen.
- **BLANK**
Push the button to temporarily interrupt the projection.
- **OVERSCAN**
Push the button to select the overscan mode.
- **FREEZE**
Freeze/cancel the freeze of the projected image.
- **LAMP MODE**
Push the button to select dual lamp, Lamp 1 Lamp 2, Single.
- **3D MODE**
Display the 3D settings menu.
- **INFO.**
Display the service menu.
- **LIGHT**
Push the button to turn on the backlight of the remote control.
- **CLEAR: No function**
- **SHUTTER**
Use the button to open/close the shutter.
- **ID SET: No function**

Remote Control Instructions

- Reflection may be affected by the environment under some circumstances. Aim the remote control at the project to try again if it happens.
* Change the battery if the effective distance of the remote control is reduced or the remote control does not work.
- When the terminal of the remote control cable is inserted to the wired control terminal of the projector, the projector will automatically switch to the wired control mode and cannot be controlled through the IR signal of the remote control. Disconnect the wired control terminal on the projector if you want to control through the IR signal of the remote control.
- Pay attention to the installation environment because the signal may not work due to interference if the IR remote sensor is exposed to the bright sunlight or fluorescence.

Installation of the Remote Control Battery

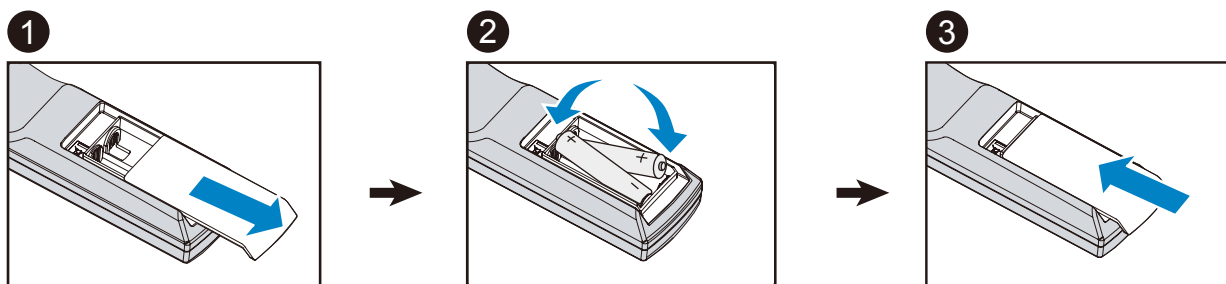

1. Slide the battery cover in the direction of the arrow.
2. Place two AA batteries with the correct polarity.
3. Slide on the cover.

Battery installation instructions

- Make sure the battery is installed with the correct polarity
- Do not use the old and new batteries or the batteries of different types together
- Remove the battery if the remote control may not be used for a long time to prevent the damage caused by leaks

Remote Control Operating Range

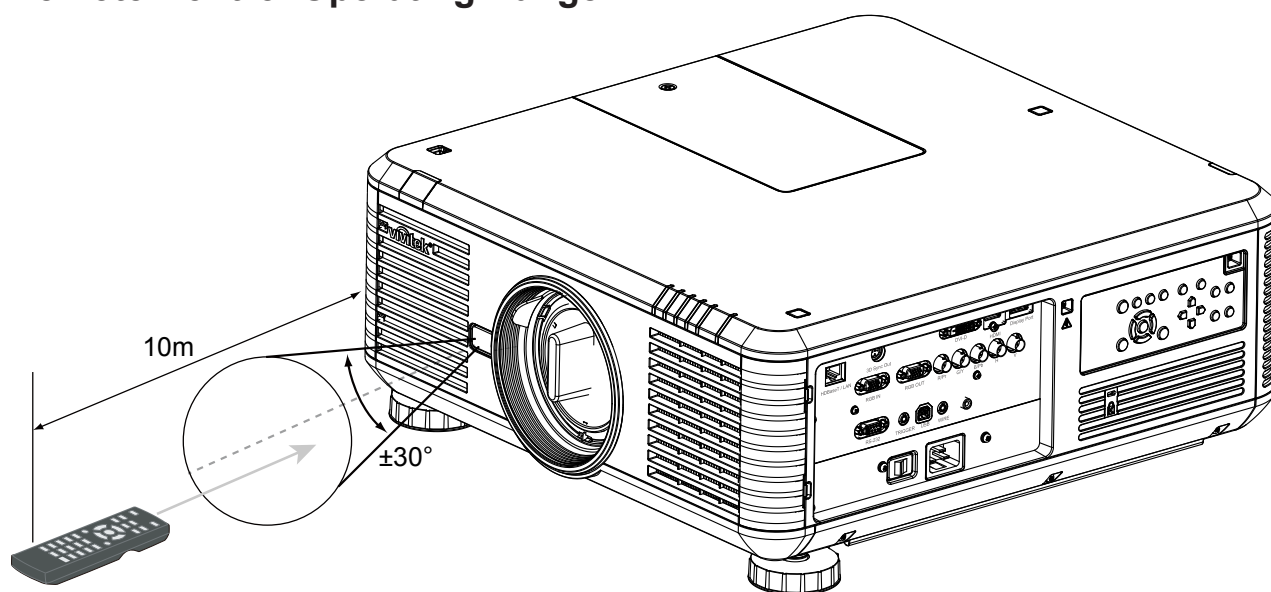

Note:

- Do not expose the remote control to high temperature or humidity; otherwise, the remote control will not work functionally.

Precautions For installation

The high quality display effect can be guaranteed only when the projector is correctly installed. Generally, the light source facing the screen should be reduced or eliminated as much as possible. The contrast of the image will be obviously reduced if the light directly shines on the screen, such as the beam from windows or the searchlight cast on the image. The image may become faded and not bright.

Projector Installation and Setup

There are 6 fixture screw holes at the bottom of projector for ceiling mounting, the available installation options as below.

Front: Install the projector on the table and project the image forward.

Rear: Install the projector on the table and project the image from rear.

Ceiling + Front: Mounting the projector on the ceiling and project the image forward.

Ceiling + Rear: Mounting the projector on the ceiling and project the image from rear.

Up + Front: Projector is mounted vertically upwards and project image upwards.

Down + Front: Projector is mounted vertically downwards and project image downwards.

6 fixture screw for ceiling mount

The screw is M4*0.7.

The maximum length of screws is 18mm.

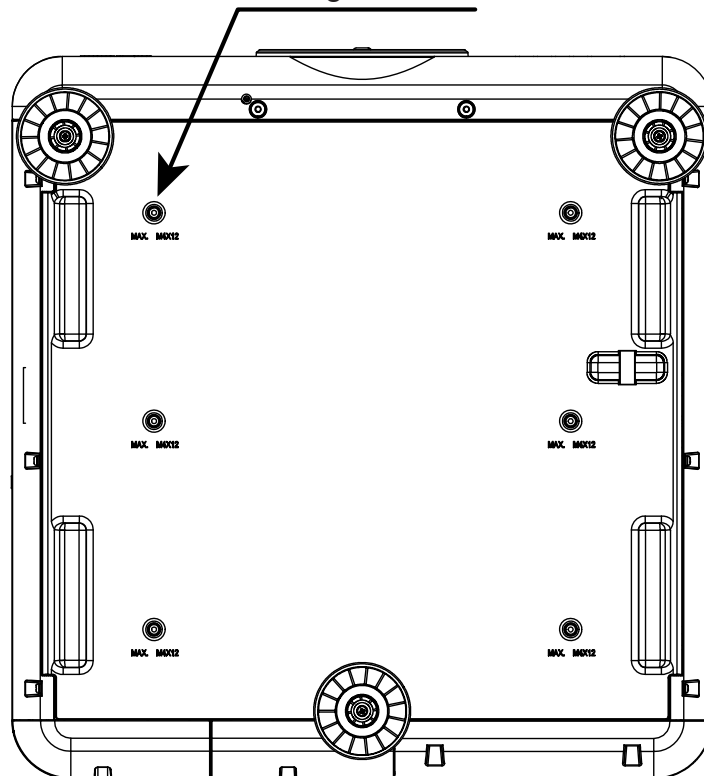

Cautions on ventilation

The product is a high-brightness projector. The intake with filters are located on the front and right sides to provide sufficient air for cooling. The projector has two vents on the back for cool air discharging. Make sure the intake and vent are unobstructed when the projector is being installed. At least 50cm around the intake and 70cm around the vent should be clear.

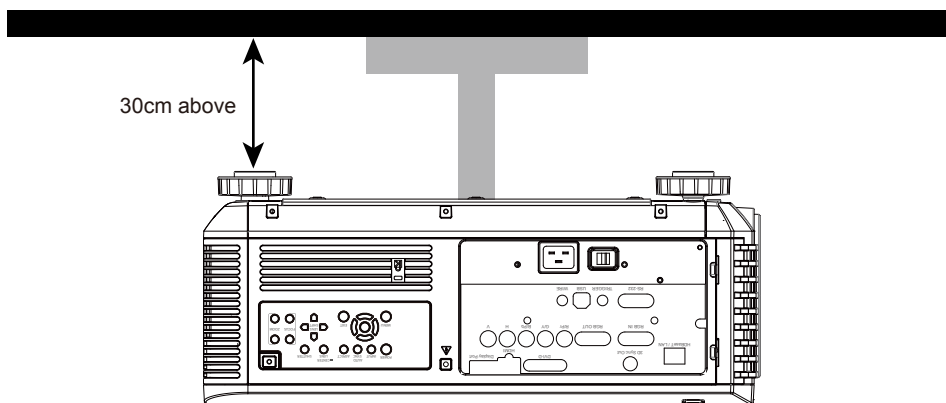
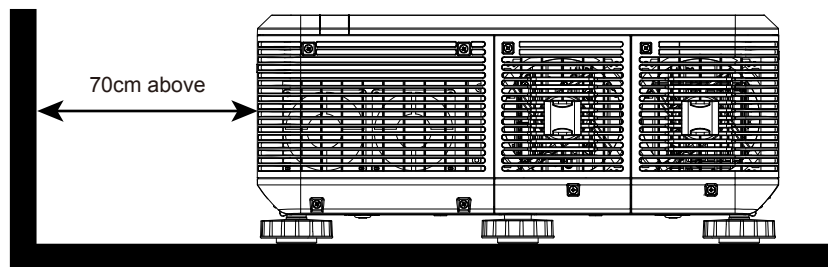
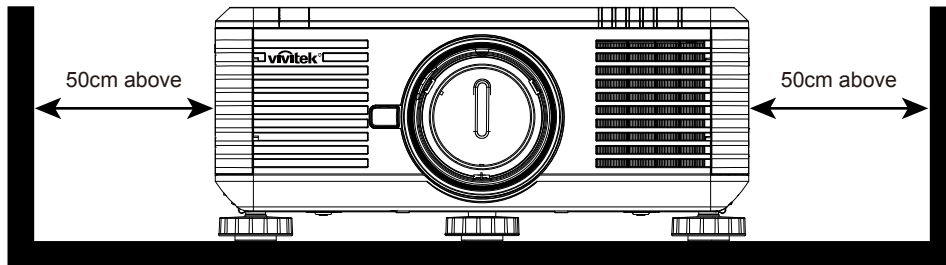

Note:

- If the installation distance is not enough, the projector may enter the system protection mode due to the rising ambient temperature after running for a while. Then, projection may be interrupted.
- The service life of components or lamps may be reduced due to the long-term effect of the ambient temperature if the installation distance is not appropriate.
- If the projector has to be installed in a box or a closed environment due to the installation requirements, the external intake and vent system should be designed additionally to ensure that there is enough air for cooling or the projector will not be surrounded by heat.

Lens Shift

The DU6871/DW6851/DX6831 projector has the lens shift feature and the image can be vertically shifted without moving the projector. The lens shift bit is shown in the percentage of the screen height. The project installed on the desk can move up and down by 50% (0.5V).

Vertical lens shift

The project installed on the desk can move up and down by 50% (0.5V).

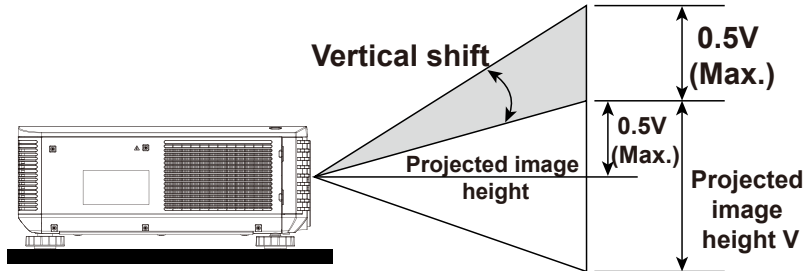

The lens of the ceiling mount projector can move down by 50% (0.5V).

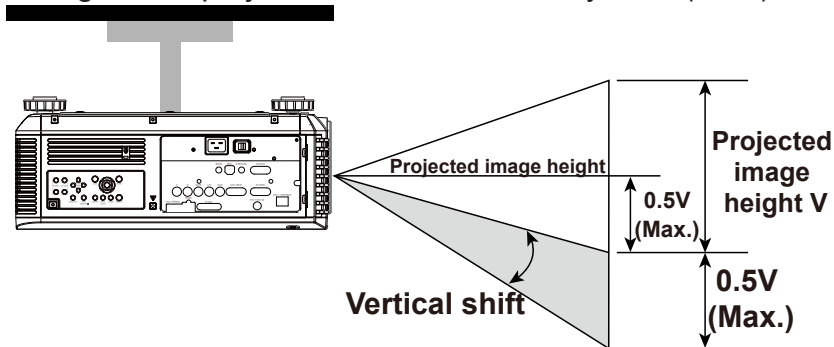

Horizontal lens shift

The image can be shifted horizontally to the right or left by 10% (0.1H) without moving the projector.

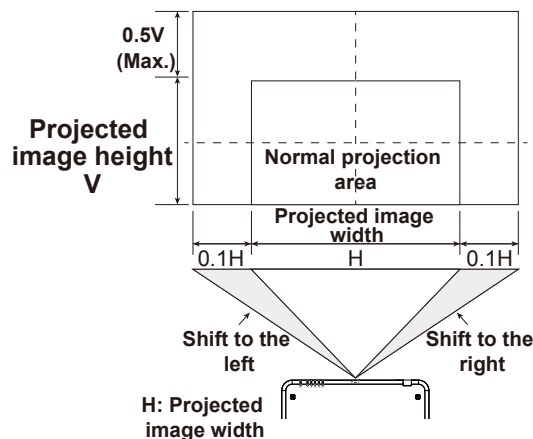

Note:

- This is the general example of lens shift. The shift ability depends on the lens. No specific lens or projector is used in the example.

Connecting the Projector to Other Equipment

Follow the instructions below to connect the DU6871/DW6851/DX6831 projector to the video source, external control equipment (if any) and AC power supply. When connecting to the equipment, use the correct signal cable to connect to every signal source and ensure that the cable is securely connected. Fasten the nut on the joint and connect the signal source equipment to the projector according to the figure below.

Connecting to the personal computer

You can connect the PC signal to be projected to the projector through the DVI-D, HDMI, DisplayPort, RGB or RGBHV (BNC) cable. If the signal to be input is VGA signal, connect the VGA cable to the external display to simultaneously monitor the projected screen.

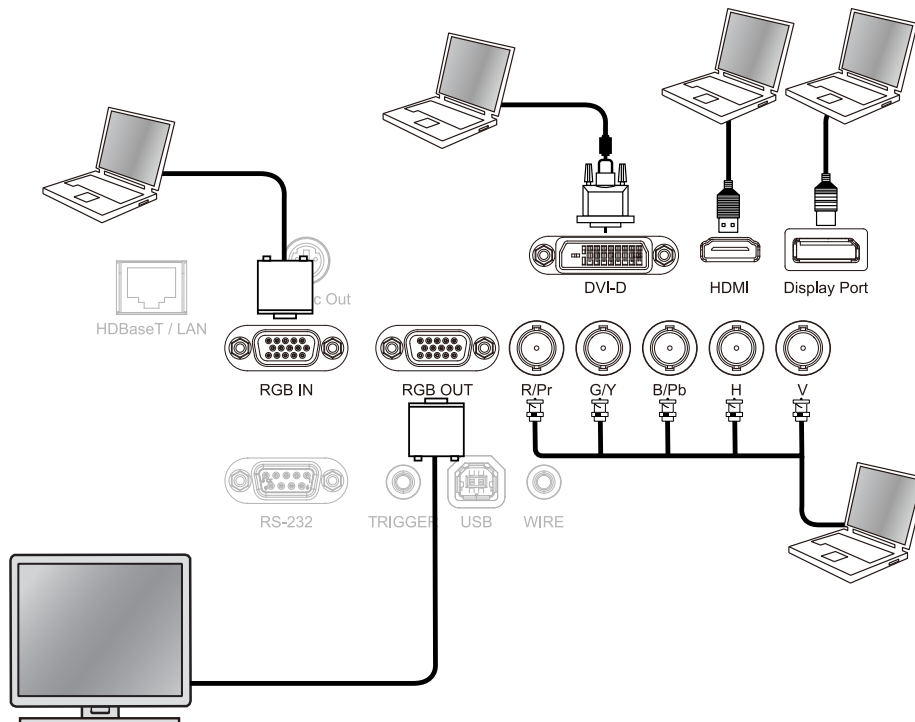

Connecting to the video equipment

Connect the video equipment to the input port of the projector via the DVI-D, HDMI, DisplayPort and Component Video Connector cable.

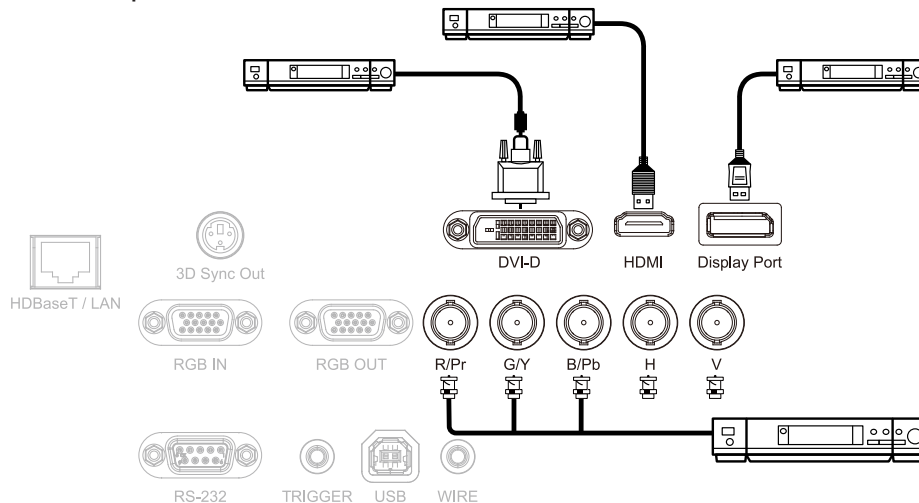

Connecting to the control equipment

The projector has the following control port for connecting to the control equipment:

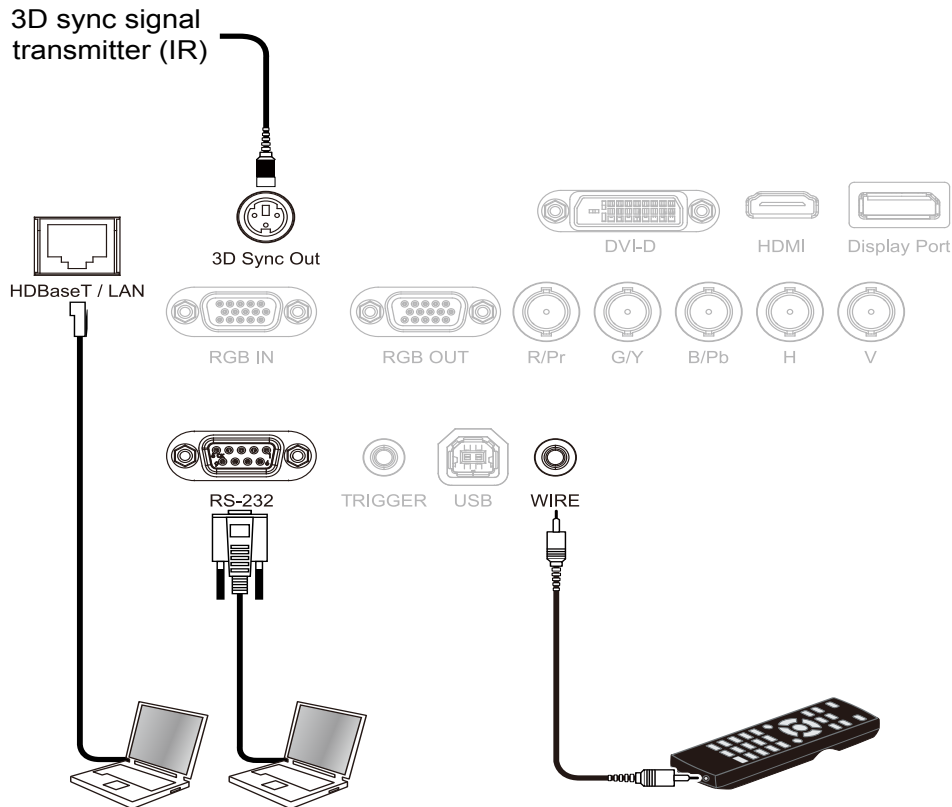

- **HDBaseT/LAN (Network control):** The projector supports network control. LAN and HDBaseT share the port. If only network control is used, you can connect the LAN on the projector to PC or through the local network. Refer to the remote control guidelines for detailed information.
- **RS-232 (RS-232c control):** The projector supports RS-232c serial control. The projector can be remote-controlled by connecting the projector to PC or control system through the standard 9-pin serial cable (Straight Through Serial Cable). Refer to the remote control guidelines for detailed information.
- **Wired remote control:** If the projector cannot receive the IR signal from the remote control due to the overly long distance or obstacles, you can connect the cable to the IR remote control or the external IR transmitter (optional) via the WIRE input port to expand the working range of the remote control.
- **3D Sync Out:** 3D IR sync signal transmitter.

Note:

- When the terminal of the remote control cable is inserted to the wired control terminal of the projector, the projector will automatically switch to the wired control mode and cannot be controlled through the IR signal of the remote control. Disconnect the wired control terminal on the projector if you want to control through the IR signal of the remote control.
- If the wired remote control cable or the external IR transmitter is inserted to the incorrect port, such as Trigger, the remote control or the IR transmitter may be damaged. Make sure whether the port is correct before insertion.

Connecting to the Screen Trigger

If your projection system includes the Electric projection screen and other 12V trigger device, you can connect these devices to the 12V trigger to output and configure the output 12V signal settings, such as automation and the aspect ratio of 16:10 through OSD control to Trigger. The projector will output 12V signals according to the current settings of the aspect ratio and trigger when turned on. You can use the signal to control the screen or device.

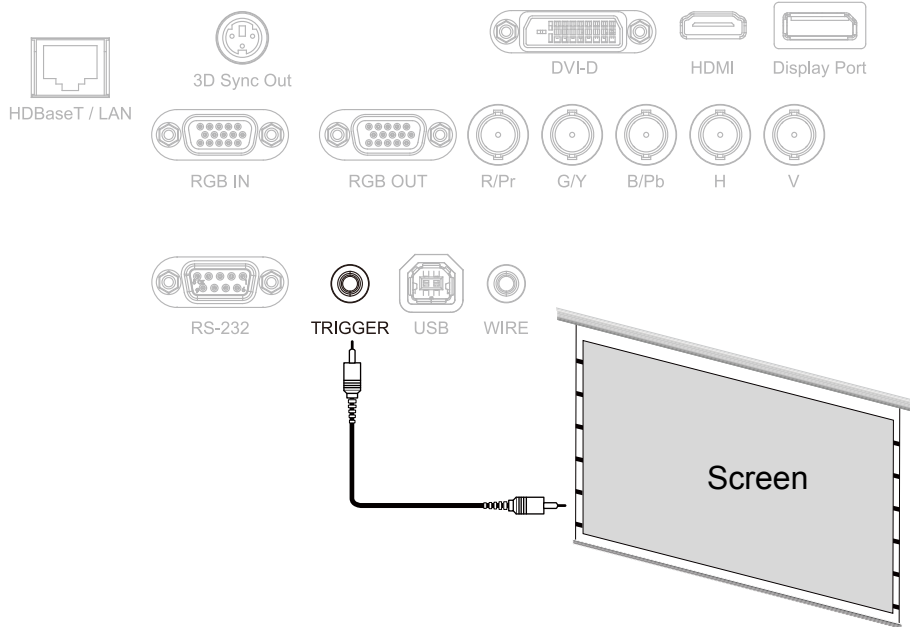

Connecting to the External HDBaseT Transmitter

The projector has a built-in HDBaseT signal receiver. With the HDBaseT Transmitter (optional), the video, RS-232 and LAN signals can be sent to the projector via a single RJ-45 cable. If the HDBaseT Transmitter you purchased supports the input and output of the IR remote control, the control signals from the IR remote control can be sent to the DU6871/DW6851/DX6831 projector via the RJ-45 cable.

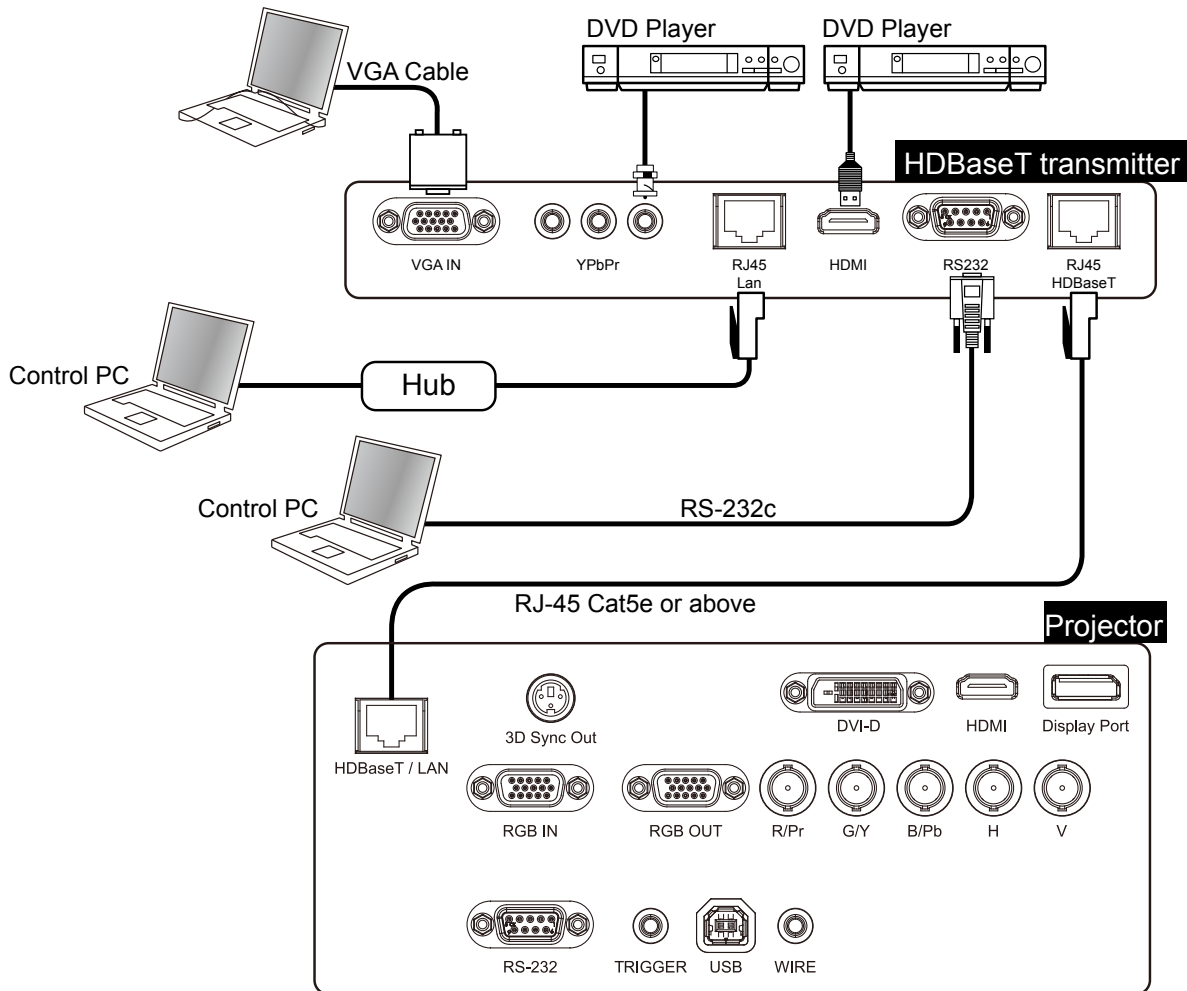

Note:

- The projector supports the video signal, R-232, IR remote control and the reception of the network control signals but do not support Power over Ethernet (PoE).
- Set the Control->RS232->Channel on the OSD menu to HDBaseT if you want to use the external HDBaseT transmitter to send the RS232 command to the projector via the RJ45 cable and baud rate will switch to 9600.
- If the command is sent via the HDBaseT transmitter, the longest transmission distance is 100 meters. The projection may be interrupted or interfered, or the control signal cannot be sent if the transmission distance is exceeded.
- Use the RJ-45 Cat5e or above cable and avoid entwining. Entwining may cause damage, interfere signal transmission, reduce the transmission distance and degrade the image quality.

Starting to Use the Projector Setup

Connecting to AC Power Supply

The AC power cord is included in the box, plug the power cord to the AC socket (AC100V-240V) on the back of the projector and plug another end of the AC power cord to the AC outlet.

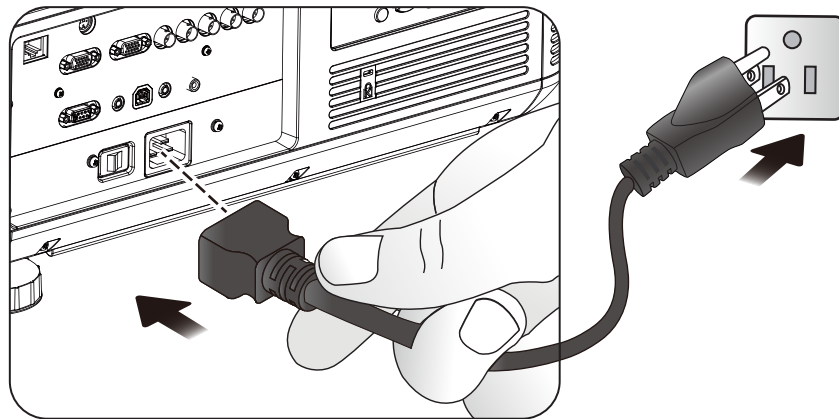

Note:

- Make sure the power system (including the project and power supply system) is properly grounded before connecting to the AC power. The projector may be damaged without the grounding circuit.
- This is a high-brightness and high-watt projector. Do not modify the AC power cord or replace the power cord arbitrarily to avoid causing damages to the projector or safety problems.

Turn on

Press ON on the remote control or POWER on the projector. The power and lamp LED indicator flashes green to show warm-up.

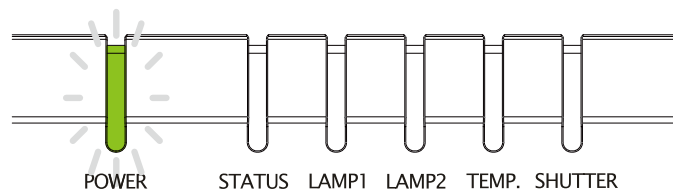
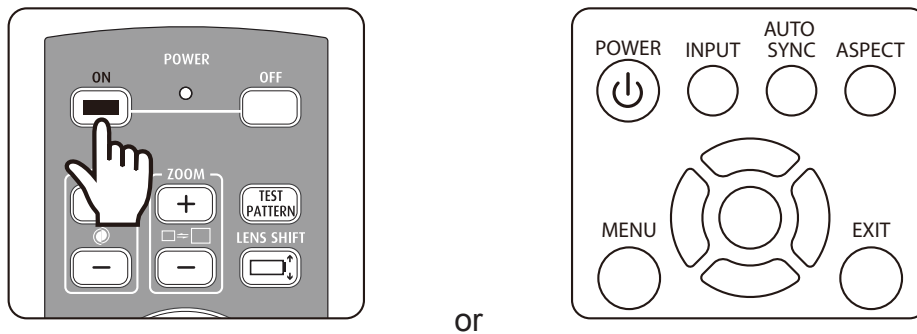

The power and lamp LED indicator will light green and the projector lights turn on when the projector is ready for use. Refer to the chapter of LED statuses if the LED indicator flashes red. Please contact the Vivitek licensed dealer if the problem cannot be solved.

Changing the OSD Language

The project can show the English, French, Spanish, German, Portuguese, Simplified Chinese, Traditional, Japanese and Korean menu. Press MENU to show OSD and press ◀▶ to select control items. Press ▲▼ to select language, ▲▼ to select the language to be used, Enter to confirm the selection.

INPUT	PICTURE	LAMP	ALIGNMENT	CONTROL	SERVICE
Eco Network Power	<	Standard	>	Language	
Auto Power off	<	Off	>	English	
Auto Power On	<	Off	>	Franais	
Projector Control	<	Both	>	Espaol	
Network		Enter		Deutsch	
RS232		Enter		Português	
Startup Logo	<	Off	>	简体中文	
Trigger	<	Off	>	繁體中文	
Auto Search	<	Off	>	日本語	
Dynamic Black	<	Off	>	한국어	
3D		Enter			
Language		Enter			

Adjusting the projection mode

The projection mode has influence on the direction of the projected image and cooling. The projection mode option can be used to change the direction of the projected screen and the cooling fan speed to ensure that the projector is properly cooled. The improper projection mode settings may trigger over temperature protection or reduce the service life of lamps and elements. Please make sure the correct projection mode is set when the projector is installed.

Press the MENU button on the remote control or the control panel to set the projection mode and select ALIGNMENT → Projection Mode

- **Front:** Installed on the desk and the projection screen will be shown in the normal direction.
- **Rear:** Installed on the desk. The image will be projected from behind the screen and the projected image will be overturned.
- **Ceiling+Front:** Ceiling mounted. The image will be projected from the front of the screen and will be overturned on 180 degree. The cooling fan speed will be adjusted.
- **Ceiling+Rear:** Ceiling mounted. The image will be projected from behind the screen and the projected image will be overturned on 180 degree. The cooling fan speed will be adjusted.
- **Up+Front:** The projector is installed upwards and the image is projected upward. The cooling fan speed will be adjusted.
- **Down+Front:** The projector is installed downwards and the image is projected downward. The cooling fan speed will be adjusted.

INPUT	PICTURE	LAMP	ALIGNMENT	CONTROL	SERVICE
Projection Mode	<	Front	>		
Fan Mode	<	Normal	>		
Lens Control		Enter			
Lens Memory		Enter			
Center Lens		Execute			
Keystone	<	0	>		
Digital Alignment		Enter			
H/V Alignment		Enter			

Lens Shift

The projector has the features to control the screen size, location and focusing. Press the Lens Shift button on the control panel or the remote control to shift, zoom in/out or focus on the projected image.

Vertical lens shift

Press ▲ ▼ to move upward or downward to vertically move the projected image.

Horizontal lens shift

Press ◀ ▶ to move to the right or left to horizontally move the projected image.

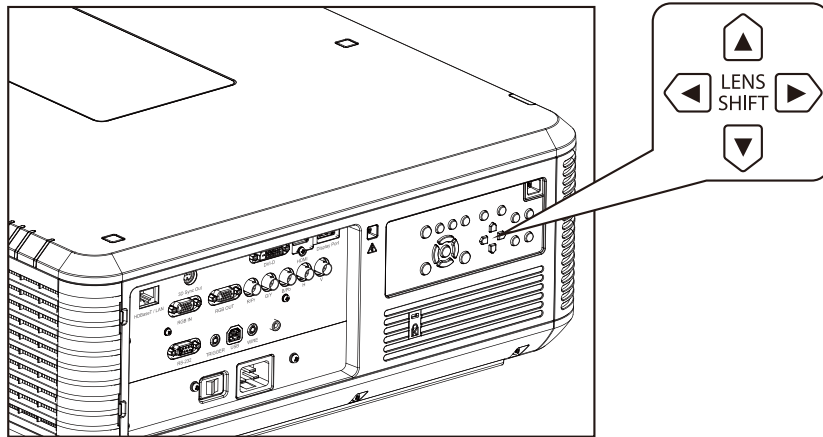

Zoom in/out

Press ZOOM+ or ZOOM- on the control panel to enlarge (zoom in) or reduce (zoom out) the projected image size.

Focus

Press ZOOM+ or - on the control panel to make the screen clear.

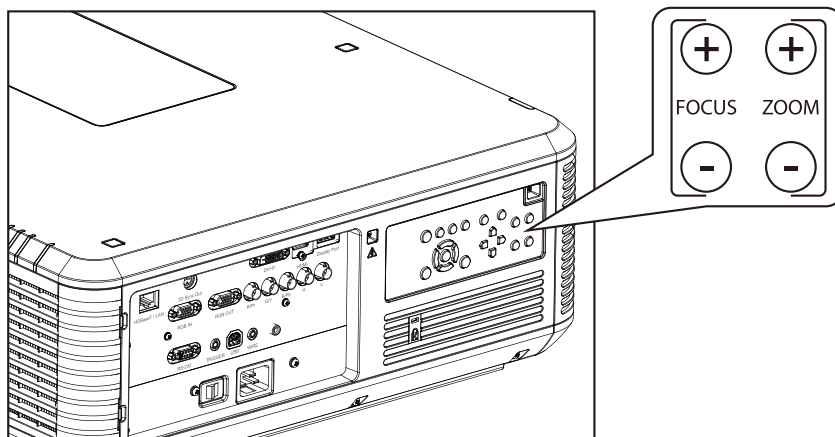

Starting to Use the Projector-Operation

Select the input source

Push the INPUT button on the remote control to directly select the input source.

Select the aspect ratio

Push ASPECT to adjust the aspect ratio of the image.

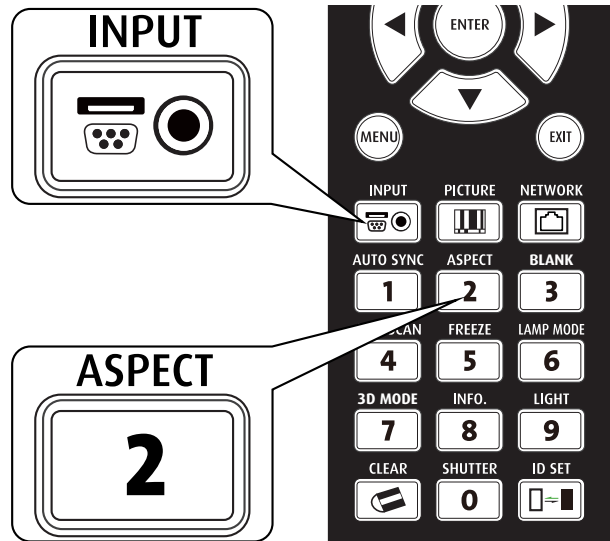

Use OSD

1. Push the MENU button on the remote control or the control panel to show the OSD main menu.
2. Press ◀ or ▶ to select the sub-menu.
3. Press ▲ or ▼ to select the item of the sub-menu.
4. The selected item will be highlighted, press ▲ or ▼ to select the settings of the item and press **ENTER** or the **ENTER** on the control panel to adjust the value of the item.
5. Press **MENU** to return to the previous menu.
6. Press **MENU** in the main menu or **EXIT** to close the OSD menu.

OSD Menu Tree

Main menu	Sub-menu				
INPUT	Input Selection	HDMI			
		DVI			
		VGA			
		Component/BNC			
		DisplayPort			
		HDBaseT			
		Test Pattern	Color Bar, Crosshatch, Burst, Red, Green, Blue, White, Black, H Ramp Uncorrected Red, Uncorrected Green, Uncorrected Blue, Uncorrected White, Uncorrected Black, Off		
Color Space	Auto				
	YCbCr				
	YPbPr				
	RGB-PC RGB-Video				
Input Lock	Auto				
	48Hz				
	50Hz				
	Blue				
Background	Logo				
	Blue				
	Black				
	White				
Auto Sync Adjust	Off				
	Auto				
	Always				
PICTURE	Picture Mode	High Bright			
		Presentation			
		Video			
	Contrast	Brightness	Saturation		
				Hue	
					Gamma
	Color	Color Temp	Graphics		
			Video		
			Linear		
2.2					
Color	Trim	Native			
		5400K			
		6500K			
		9300K			
Color	Trim	Red Lift			
		Green Lift			
		Blue Lift			

Main menu	Sub-menu		
PICTURE	Color	Trim	Red Gain
			Green Gain
			Blue Gain
		Hue	Red
			Green
			Blue
			Cyan
			Magenta
			Yellow
		Saturation	Red
			Green
			Blue
			Cyan
			Magenta
			Yellow
	Gain	Red	
		Green	
		Blue	
		Cyan	
		Magenta	
		Yellow	
White Balance	Red		
	Green		
	Blue		
Auto Sync	Sharpness		
	Noise Reduction		
	Aspect Ratio	05:04	
		04:03	
		16:10	
		16:09	
		1.88:1	
		2.35	
		LetterBox	
		Native	
	Unscaled		
	Overscan	Off	
		Crop	
		Zoom	
	VGA Setup	H Total	
H Start			
H Phase			
V Start			
LAMP	Mode	Dual Lamp	
		Lamp 1	
		Lamp 2	
		Single	

Main menu	Sub-menu		
LAMP	Power	Normal	
		Eco	
		Custom Power Level	
	High Altitude	On	
		Off	
Lamp 1 Status			
Lamp 2 Status			
ALIGNMENT	Projection Mode	Front	
		Rear	
		Ceiling + Front	
		Ceiling + Rear	
		Up + Front	
		Down + Front	
	Lens Control	Zoom	
		Focus	
		Shift V	
		Shift H	
	Lens Memory	Load Memory	Memory Set 1 to 10
		Edit Memory	Memory Set 1 to 10
	Center Lens	Execute	
	Digital Alignment	Digital Zoom	
Digital Pan			
Digital Scan			
Reset			
H/V Alignment	H Zoom		
	V Zoom		
	H Shift		
	V Shift		
	Reset		
CONTROL	Standby Mode	Standard	
		Eco	
	Auto Power Off	On	
		Off	
	Auto Power On	On	
		Off	
	Projection control	RS232	
		Network	
		Automatic switch	
	Network	IP Address	
		Subnet	
		Gateway	
DHCP		On Off	
Apply			
RS232	Baud Rate	115200/57600/38400/19200/ 14400/9600/4800/2400/1200	

Main menu	Sub-menu			
CONTROL	RS232	Channel	Local HDBaseT	
		Startup Logo	On Off	
		Trigger	05:04 04:03 16:10 16:09 1.88 2.35 Letter Box Native	
		Auto Search	On Off	
		Dynamic Black	On Off	
		3D	3D Format	Off Auto Side by Side Top/Bottom Frame Sequential
			DLP Link	On Off
			3D Swap	Normal Reverse
			3D 24Hz Display	96Hz 144Hz
			Language	English/Français/Español/ Deutsch/Português/ 简体中文 / 繁體中文 / 日本語 / 한국어
	SERVICE		Model	
			Serial Number	
			Software Version	
			Active Source	
			Pixel Clock	
			Signal Format	
			H/V Refresh Rate	
		Lamp 1 Time		
		Lamp 2 Time		
		Blue Only	On Off	
		Factory Reset	OK Cancel	

OSD Menu - INPUT

INPUT	PICTURE	LAMP	ALIGNMENT	CONTROL	SERVICE
Input Selection		Enter			
Test Pattern		Enter			
Color Space	<	AUTO	>		
Input Lock	<	AUTO	>		
Background	<	LOGO	>		
Auto Sync Adjust	<	Always	>		

- **Input Selection**

This function is same as the shortcut key on the remote control. You can use the remote control or this function to select the correct input source.

- **HDMI**

HDMI input in PC or media equipment.

- **DVI**

DVI input in PC.

- **VGA**

RGB signal in PC.

- **Component/BNC**

Analog/serial digital interface in media equipment.

- **DisplayPort**

DisplayPort input in PC or media equipment.

- **HDBaseT**

HDBaseT output of PC, media equipment or HDbaseT transmitter.

- **Test Pattern**

The built-in image is provided for installation and adjustment. You can select Test Pattern on OSD or the TEST PATTERN button on the remote control to display the test pattern. Press the button again to display the next test pattern or press the Exit button to exit the test pattern.

- **Color Space**

This function allows you to change the corresponding color space for the input signal. In most cases, the correct color space can be selected automatically by Auto mode. If the selection is not correct, you can use a specific color space forcibly by selecting one of the following options:

Auto: The projector detects the input signal and switches to the corresponding color space automatically.

YCbCr: Set the color space to ITU-R BT.601.

YCbCr: Set the color space to ITU-R BT.709.

RGB-PC: Use the RGB color space and set the black to 0, 0, 0 RGB while set the white to 255, 255, 255 RGB (if a 8-bit image is used).

RGB-Video: Use the RGB color space and set the black to 16, 16, 16 RGB while set the white to 235, 235, 235 (if a 8-bit image is used) to correspond to the luminance value defined in the digital component standard.

- **Input Lock**

You can use this function to lock an input source to the internal sync signal (Auto, 48Hz, 50Hz or 60 Hz). The sync signal is locked to the current signal source if it's set to Auto.

- **Background**

You can use this function to specify the image to be displayed on the blank screen when no signal is input. You can select the Startup logo, Blue, Black, or White. The default is Startup logo.

- **Auto Sync Adjust**

You can use this function to set auto synchronization for the input signal.

Auto: The projector memorizes 10 sets of signal sources that you have used lately.

When the Auto option is selected, the projector will choose the signal that you use last time.

Always: The auto sync function is executed every time.

OSD Menu - PICTURE

INPUT	PICTURE	LAMP	ALIGNMENT	CONTROL	SERVICE
Picture Mode	<	Video	>		
Contrast	<	100	>		
Brightness	<	100	>		
Saturation	<	100	>		
Hue	<	100	>		
Color		Enter			
Sharpness	<	15	>		
Noise Reduction	<	0	>		
Aspect Ratio	<	16:10	>		
Overscan	<	Off	>		
VGA Setup		Enter			
Auto Sync		Execute			

- **Picture Model**

Use ◀▶ to select a picture model.

High Bright: The highest brightness output mode is suitable for the occasion where high brightness is needed.

Presentation: The best image effect is suitable for the presentation or picture.

Video: The best color mode is suitable for play of the video.

- **Contrast**

Use ◀▶ to adjust the contrast of the projected image.

Note:

- *The brightness and contrast controls affect each other. To obtain the best setting, fine-tune of the brightness setting might be needed after adjustment of the contrast.*

- **Brightness**

Use ◀▶ to increase or decrease the brightness of the image.

- **Saturation**

Use ◀▶ to adjust the saturation level of the color (the higher the level, the higher the saturation).

- **Hue**

Use ◀▶ to adjust the level of hue for reproduction of the true color.

- **Gamma**

When the ambient light is too bright and may affect the display of the details in the darker area of the image, you can select from the following gamma options to adjust the chrominance of the image.

Film: Set the chrominance correction to approximately Gamma 2.2.

Graphics: This options is used for the PC presentation that needs higher brightness at the cost of the gray scale accuracy.

Video: This is similar to the Film option, but there is a different in the dark area of the image to correspond to the function that the camera uses for creation of the image.

Linear: Set Gamma to linear chrominance correction.

2.2: Set the chrominance correction to 2.2.

- **Color**
Use ◀▶ to adjust the color temp of the projected image.
- **Sharpness**
Use ◀▶ to adjust the sharpness. The purpose of this adjustment is to change the value of the high-frequency detail.
- **Noise Reduction**
Use ◀▶ to adjust the noise of the projected image. This function is suitable for removing the noise of the image in interlaced scanning input. Generally, noise reduction can lower the value of the high-frequency detail and make the image softer.
- **Aspect Ratio**
This function allows the user to adjust the aspect ratio of the image.

With a normal input of 16:10, the aspect ratio:

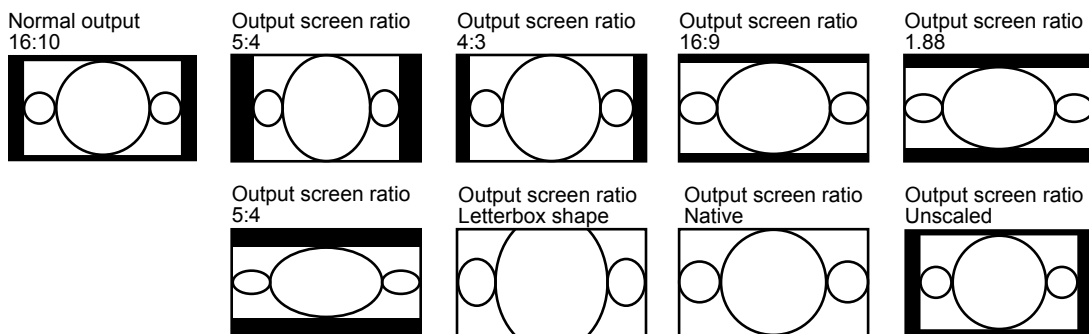

With a normal input of 4:3, the aspect ratio:

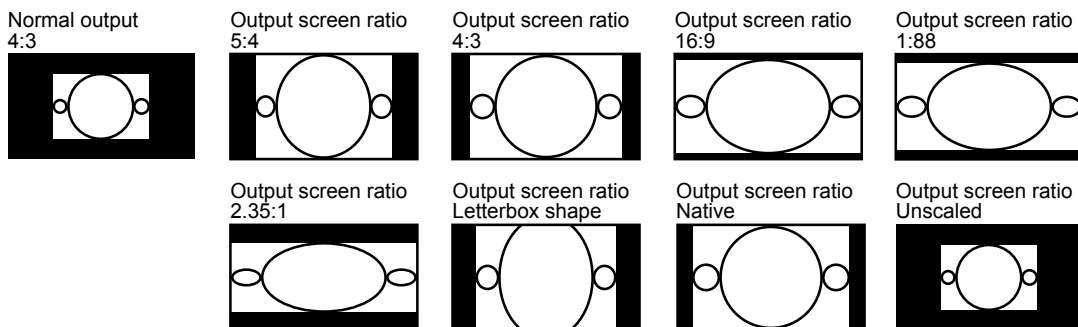

- **Overscan**
Noise may appear on the edge of the projected image, use this function to select one of the following options to hide the edge of the image:
- **VGA Setup**
Set the H Total, H Start, H Phase and V Start for the VGA signal display.
- **Auto Sync**
Use this function to execute the Auto Sync input signal.

OSD Menu - LAMP

INPUT	PICTURE	LAMP	ALIGNMENT	CONTROL	SERVICE
Mode		Enter			
Power		Eco			
High Altitude	<	Off	>		
Custom Power Level	<	-----	>		
Lamp 1 Status		On			
Lamp 2 Status		Off			

- **Mode**

Use the ◀▶ function to select the single-lamp or dual-lamp mode.

Dual: Enable the dual-lamp projection mode.

Lamp 1: Use Lamp 1 for projection. The system switches to Lamp 2 if Lamp 1 is abnormal in activation.

Lamp 2: Use Lamp 2 for projection. The system switches to Lamp 1 if Lamp 2 is abnormal in activation.

Single: Use the single-lamp mode for the projection. The lamp is not specified in this mode, the projector selects the lamp that has the least operation hours automatically whenever it is turned on.

Note:

1. In the Lamp 1 or Lamp 2 mode, the projector will switch to another lamp when the set lamp becomes abnormal. The corresponding LED indicator of the lamp will flash simultaneously for seconds and light up.
2. When the lamp mode is set to Single, the setting will become valid upon turn-on of the projector next time.
3. Quick switch of the lamp mode may affect the life of the lamp. The projector will disable the lamp mode function (highlighted) every time when a switch is conducted till the switch of the lamp mode is completed. The lamp mode options are not available before the switch of the lamp mode is completed.

- **Power**

Use the ◀▶ function to select the ECO, Normal or Custom Power Level mode.

Normal: Projection is carried out using the normal lamp power to obtain the brightest projection display.

ECO: Projection is carried out in the energy saving mode to ensure the longest service life of the lamp.

Custom Power Level: In addition to the Normal and ECO modes, the lamp power equal to 100% to 75% of the power in the Normal mode is used for fine-tune of the brightness in the Custom Power Level mode. This function can be used for quick installation and routine maintenance in multi-projector applications. Select this mode to enable the Custom Power Level function.

- **High Altitude**

Use this function to control the cooling fan of the projector. You can set it to OFF or ON, the default setting is OFF.

Normally, the projector can operate normally when this function is set to OFF. The projector detects ambient temperature by default to regulate the cooling fan speed. When the temperature rises, the cooling fan speeds up (with higher noise) to exhaust the internal heat energy out of the projector and ensure its normal operation. However, the projector may turn off automatically if it is used in an environment at excessively high temperature or in an area at a high altitude. In this case, you can enable this function by setting it to ON and have the cooling fan operate at a higher speed to control the internal temperature of the projector.

Note:

- *The area at a high altitude means the place at an altitude of more than 5000 feet.*

- **Custom Power Level**

Use the ◀▶ function to select the Custom Power Level. The projector allows a custom power level equal to 100%~75% of the lamp power in the Normal mode. This function is available only when the lamp power is set to Custom Power Level. It cannot be selected (highlighted) in the Normal or ECO mode.

- **Lamp 1 Status**

Show the current status of Lamp 1 (ON/OFF)

- **Lamp2 Status**

Show the current status of Lamp 2 (ON/OFF)

OSD Menu - ALIGNMENT

INPUT	PICTURE	LAMP	ALIGNMENT	CONTROL	SERVICE
Projection Mode	<	Front	>		
Lens Control		Enter			
Lens Memory		Enter			
Center Lens		Execute			
Keystone	<	0	>		
Digital Alignment		Enter			
H/V Alignment		Enter			

- **Projection Mode**
Use the ◀▶ function to select a projection mode: Front, Rear, Ceiling + Front, Ceiling + Rear, UP and Down.
- **Lens Control**
Select this function to open the Lens Control menu for adjustment of Zoom, Focus or Shift. You can use the Enter button to switch the Zoom/Focus or Shift menu. Use ◀▶ to adjust zooming and horizontal shift of the lens, or use ▲▼ to adjust focusing and vertical shift of the lens.

Lens Control	Lens Control
Zoom ▲ ▼	Shift V ▲ ▼
Focus ◀ ▶	Shift H ◀ ▶
Enter to Shift	Enter to Zoom/Focus

• **Lens Memory**

This projector supports the lens zooming, focusing and lens shift memory function. Up to 10 sets of settings can be stored. The name setup in the memory can be input from the keyboard simulator. You can store the current lens position (H/V), zoom and focus, use the Load Memory function to load the stored lens setting values. The projector will adjust to the corresponding lens shift, zoom and focus settings automatically.

INPUT	PICTURE	LAMP	ALIGNMENT	CONTROL	SERVICE
Projection Mode	<	Front	>	Lens Memory	
Lens Control		Enter	Load Memory	Enter	
Lens Memory		Enter	Edit Memory	Enter	
Center Lens		Execute	Load Memory		
Keystone	<	0	>	■ STD 4:3	Enter
Digital Alignment		Enter	Memory 2	Enter	
H/V Alignment		Enter	Memory 3	Enter	
			Memory 4	Enter	
			Memory 5	Enter	
			Memory 6	Enter	
			Memory 7	Enter	
			Memory 8	Enter	
			Memory 9	Enter	
			Memory 10	Enter	

Load Memory

Call back the lens setting that you have set and press the Enter button to display the lens memory list. Use ▲▼ to select the lens memory setting that you have set and press the Enter button to execute the lens setting.

The projector supports up to 10 sets of lens settings. The lens memories that you have set are indicated with different colors. Only the lens memory that you have set can be selected from the list. To add or modify any lens memory, please perform the Edit Memory function.

Edit Memory

You can set the name using the Edit Memory function and store the current lens settings including the lens shift, zoom and focus.



Press the Enter button to display the Edit Memory window and keyboard simulator. Use ▲▼◀▶ and the Enter button to select or confirm the setting.

Change the name of the memory: The default name is Memory_number. You can use the Back space button to delete the characters in the dialog box. The Caps button is used to selected uppercase and lowercase characters. Use ▲▼◀▶ to select the character and press the Enter button to confirm the input character. The maximum allowable 9 characters including texts, numbers, symbols and spaces.

Cancel: Press the Cancel button to cancel the memory setting.

Accept: Press the Accept button to confirm the memory setting.

Clear Memory: Select the Clear Memory button and press the Enter button to confirm cancellation of the selected setting. A prompt of the confirmation is shown on the button. To confirm the cancellation of the selected setting, press the Enter button. Otherwise, Use ▲▼◀▶ to move the cursor away and do not cancel the selected setting.

Note:

- *The Lens Memory function must be used in conjunction with VivitekD88-ST001, D88-UWZ01, D88-WF18501, D88-WZ01, D88-SMLZ01, D88-LOZ101 or D88-LOZ201 serial lens.*
- *To ensure that the projector can remember the lens parameters precisely, make sure to perform the Center Lens function whenever a lens is mounted.*

- **Center Lens**

This is the lens calibration function. The projector adjusts the lens parameters for the lens memory function to work and sets the lens to the default center position.

- **Keystone**

Select the Keystone function and use ◀▶ to adjust the screen for the vertical distortion brought about by the projection angle.

• **Digital Alignment**

INPUT	PICTURE	LAMP	ALIGNMENT	CONTROL	SERVICE
Projection Mode	<	Front	>	Digital Alignment	
Lens Control		Enter	Digital Zoom	< 0 >	
Lens Memory		Enter	Digital Pan	< 0 >	
Center Lens		Execute	Digital Scan	< 0 >	
Keystone	<	0	>	Reset	Execute
Digital Alignment		Enter			
H/V Alignment		Enter			

Select this function to enlarge the projected image.

Digital Zoom: Use ◀▶ to enlarge the projected image.

Digital Pan: Use ◀▶ to move the projected image horizontally. This function is only available when the projected image is enlarged.

Digital Scan: Use ◀▶ to move the projected image vertically. This function is only available when the projected image is enlarged.

Reset: Set the Digital Alignment back to the factory default value.

• **H/V Alignment**

H Zoom: Use ◀▶ to narrow the horizontal size of the projected image.

V Zoom: Use ◀▶ to narrow the vertical size of the projected image.

H Shift: Use ◀▶ to move the narrowed projected image horizontally. This function is only available when the projected image is narrowed.

V Shift: Use ◀▶ to move the narrowed projected image vertically. This function is only available when the projected image is narrowed.

Reset: Set the H/V Alignment back to the factory default value.

OSD Menu - CONTROL

INPUT	PICTURE	LAMP	ALIGNMENT	CONTROL	SERVICE
Standby Mode	<	Standard	>		
Auto Power off	<	Off	>		
Auto Power On	<	Off	>		
Network		Enter			
RS232		Enter			
Startup Logo	<	Off	>		
Trigger	<	Off	>		
Auto Search	<	Off	>		
Dynamic Black	<	Off	>		
3D		Enter			
Language		Enter			

- **Standby Mode**

Use the ◀▶ function for "Standard" or "Eco" setting.

Standard Model: The projector can be turned on using the remote control, RS-232 command or network control.

Eco: The projector maintains in the standby status at the lowest power (<0.5W). In this mode, the projector can be turned on only using the power switch on the remote control or projector.

- **Auto Power Off**

This function is set to OFF by default. When it is set to ON and no input signal is received within 20 minutes, the projector will turn off automatically.

- **Auto Power On**

This function is set to OFF by default. When it is set to ON, the projector will turn on automatically when you connect it to an AC power source. When you plug the power cable of the projector in an AC socket attached with a switch, you can use this function and the power switch (instead of the remote control) to turn on the projector. Set this function to OFF if you do not need to use it.

INPUT	PICTURE	LAMP	ALIGNMENT	CONTROL	SERVICE
Standby Mode	<	Standard	>	Network	
Auto Power off	<	Off	>	IP Address	< xxx.xxx.xxxx.xxx >
Auto Power On	<	Off	>	Subnet	< 255.255.255.0 >
Network		Enter		Gateway	< xxx.xxx.xxxx.xxx >
RS232		Enter		DHCP	Off
Startup Logo	<	Off	>	Apply	Apply
Trigger	<	Off	>		
Auto Search	<	Off	>		
Dynamic Black	<	Off	>		
3D		Enter			
Language		Enter			

- Network**

Use this function to set up network configurations so that you can control the projector via the network.

Use ▲ ▼ and the Enter button to select Network and network settings:

IP Address: To specify an IP address, press the Enter button to show the IP address input window. Use the ◀▶ button to select the number in the address to be changed. Use the ▲ ▼ button to increase or decrease the number in the IP address.

Network	
IP Address	172 . xxx . xxx . xxx

Subnet: Set the subnet. The input method is same as the IP address.

Gateway: Set the gateway. The input method is same as the IP address.

DHCP: Set DHCP to ON/OFF. When DHCP is set to ON, the DHCP server of the domain will assign an IP address to the projector. The IP address will appear in the IP address window and you don't need to make any input. Otherwise, the domain does not or cannot assign any IP address, and 0. 0. 0. 0 is shown on the IP address window.

Apply: Select this button and press Enter. It takes the projector several seconds to execute the change of the network setting till the following message disappears.

Setting network configuration, please wait

For more information about the network control connection and setting, refer to Remote Control Guide.

- RS232**

Baud Rate: Set the transmission rate to 115200, 57600, 38400, 19200, 14400, 9600, 4800, 2400 or 1200. The setting of the transmission rate is dependent on the length of the RS-232 cable. Low transmission rate is usually set for long transmission cables. If RS-232 is used for remote control and the signal is unstable or no communication is connected, select a suitable transmission rate.

Channel: The RS232 control command can be sent to the projector through its RS-232 port. The command can also be sent to the projector through the external HDBaseT connecting to the RJ-45/HDBaseT port. Set the following communication channels before sending the control command:

Local: The RS-232 control command is sent through the RS-232 port on the projector. Select an appropriate transmission rate.

HDBaseT: Transmission is conducted from the external HDBaseT to the RJ-45/HDBaseT port on the projector. The transmission rate is switched to 9600.

Note:

- When the Standby Mode is set to the Eco Mode, the LAN and RS-232 control function is turned off. Therefore, the projector can only be turned on using the remote control or the button on the projector. Before using RS232 or LAN control, set the Standby Mode to Standard.

- **Startup Logo**

Use the ◀▶ function to turn on/off the Startup Logo.

- **Trigger**

The projector is provided with a set of trigger output. When automatic screen equipment is available, connect it to the screen trigger of the projector using the cable. The screen automatically turns on when the projector is powered on. There is a 2-3 second delay before this function is activated.

5:4: When the 5:4 aspect ratio is selected, the trigger outputs 12V power.

4:3: When the 4:3 aspect ratio is selected, the trigger outputs 12V power.

16:10: When the 16:10 aspect ratio is selected, the trigger outputs 12V power.

16:9: When the 16:9 aspect ratio is selected, the trigger outputs 12V power.

1.88: When the 1.88 aspect ratio is selected, the trigger outputs 12V power.

2.35: When the 2.35 aspect ratio is selected, the trigger outputs 12V power.

Letterbox: When the aspect ratio having the letterbox shape is selected, the trigger outputs 12V power.

Standard: When the native aspect ratio is selected, the trigger outputs 12V power.

Unscaled: When the unscaled aspect ratio is selected, the trigger outputs 12V power.

Auto: The trigger automatically outputs 12V power.

- **Auto Search**

Use the ◀▶ function to turn on/off Auto Search.

- **Dynamic Black**

Use the ◀▶ function to turn on/off Dynamic Black.

- **3D**

Set the 3D format and sync method. The projector detects the type of the connected input signal and provides relevant options for setting. The unavailable option is displayed using light green texts. Before performing the 3D setting, ensure that the input signal is connected. When there's no input signal, no 3D setting shall be performed.

INPUT	PICTURE	LAMP	ALIGNMENT	CONTROL	SERVICE
Standby Mode	<	Standard	>	3D	
Auto Power off	<	Off	>	3D Format	Enter
Auto Power On	<	Off	>	DLP Link	< On >
Network		Enter		3D Swap	< Normal >
RS232		Enter		3D 24Hz Display	< 96Hz >
Startup Logo	<	Off	>	3D Format	
Trigger	<	Off	>	■ Off	Execute
Auto Search	<	Off	>	Auto	Execute
Dynamic Black	<	Off	>	Side by Side	Execute
3D		Enter		Top / Bottom	Execute
Language		Enter		Frame Sequential	Execute

3D Format: Select this option and press the Enter button to enable 3D replay and set 3D option.

Off: Turn off the 3D Display Mode. When Auto, Side by Side, Top/Bottom or Frame Sequential is selected, the 3D Mode will be turned on. To turn off the 3D Mode, select "Off" and press the Enter button.

Auto: Enable the 3D format to automatically detect the formats of Frame Packing, Top/Bottom, Side by Side and Frame Packing.

This function may only be enabled for the input signal below

- The input signal is HDMI 1.4a 3D.
- The HDMI 1.4a 3D signal connects to the projector through the HDBaseT transmitter.

Side by Side: Manually switch the 3D Format to Side by Side. This option is only applicable to the HDMI input signal or the HDMI signal sent using the HDBaseT transmitter.

Top/Bottom: Manually switch the 3D Format to Side by Side. This option is only applicable to the HDMI input signal or the aforementioned signal sent through the HDBaseT transmitter.

Frame Sequential: Set the format to Frame Sequential.

DLP Link: Set to activate or deactivate the DLP Link sync.

3D Swap: If the 3D imaged viewed through the 3D glasses for the left and right eyes are inverse, set the 3D Swap to "Inverse". If the images are normal, keep the current setting as Normal.

3D 24Hz Projection: Set the 3D 24Hz image frame rate to 144fps or 96fps. This option is only applicable when the input signal is 24Hz.

Note:

- *The projector provides DLP Link and 3D IR sync. After the 3D Mode is enabled, the built-in DLP Link or external 3D IR transmitter can be used to synchronize the signal of the 3D glasses. Or, you may turn off the DLP Link sync signal and only select the external 3D IR transmitter to synchronize the 3D signal.*

Important reminder:

- The people listed below shall be aware when watching 3D images:
 - Children under six years in age
 - People who are allergic to light, unhealthy and have the history of cardiovascular disease.
 - People who are tired or lack of sleep
 - People who are under the impact of drug or alcohol
- Normally, it's safe to watch 3D images. However, some people might feel uncomfortable. Refer to the guidelines revised and released by the 3D League on December 10, 2008. People need to take a break for at least 5 to 15 minutes every thirty minutes or one hour.

- **Language**

Select the familiar OSD Menu language. English, French, Spanish, German, Portuguese, Simplified Chinese, Traditional, Japanese and Korean.

OSD Menu - SERVICE

INPUT	PICTURE	LAMP	ALIGNMENT	CONTROL	SERVICE
Model :		DU6871			
Serial Number :		XXXXXXX			
Software Verison :		MPxx-0Dxx-UDxx-RDxx-SExx-PDxx-xxxx			
Active Source		VGA			
Pixel Clock		64.977 MHZ			
Signal Format		1024x768 @60Hz			
H/V Refresh Rate :		H: 49.578 KHZ V: 60 HZ			
Lamp 1 Time		168 HRS			
Lamp 2 Time		168 HRS			
Power On Time		168hrs			
Blue Only		< Off >			
Factory		Execute			

The functions of the projector are related to the display of some basic information of the projector.

- **Model**
Projector model name.
- **Serial Number**
Projector serial number.
- **Software Version**
The version of the software installed in the projector.
- **Active Source**
Display the current source.
- **Pixel Clock**
Display the pixel clock of the current input signal.
- **Signal Format**
Display the format of the current input signal.
- **H/V Refresh Rate**
Display the H/V refresh rate of the current image.
- **Lamp 1 Time**
Display the using hours of Lamp 1.
- **Lamp 2 Time**
Display the using hours of Lamp 2.
- **Power On Time**
Display the operation Time.
- **Blue Only**
The projector only displays blue when this option is enabled. This can help the maintenance personnel to inspect the image. Contact professional maintenance personnel for the details about the way to use this function.
- **Factory Reset**
Use this function to restore the configuration of the menu to the factory default setting. All of the user setting options of the projector will be deleted and restored to the factory default settings.

Note:

- Restoration to factory default settings will not delete and reset the lamp hours.

Replacing the Lamps

Depending on the lamp model, the lamp life is affected by the installation method and frequency of the lamp on/off operation. It is suggested to replace the projector lamp when the lamp is used for approximately 1500 hours to ensure high projection quality. In the OSD Menu, the lamp using time can be checked from the "OSD Menu - Service". The lamp should be replaced when the projected image is obviously darkened. Contact your local dealer to purchase the authorized new lamp suitable for your projector.

Note:

- Purchase the lamp module produced by Vivitek. Using the lamp that is not made by Vivitek may affect the performance of the projector or damage the projector.

How to replace the projector lamp

1. Turn off the projector and unplug the power cord. Wait till the projector, lamp and peripheral devices to cool off. Then remove the lamp module for replacement.

Note:

- When the projector is just turned off, the temperature of the lamp inside the projector is still very high (about 200~300°C). You might be burnt if attempting to replace the lamp when the projector is not cooled off. The lamp can be replaced safely when the lamp is cooled off.

2. Remove the screw with the screwdriver ① and take the lamp cover out ②.

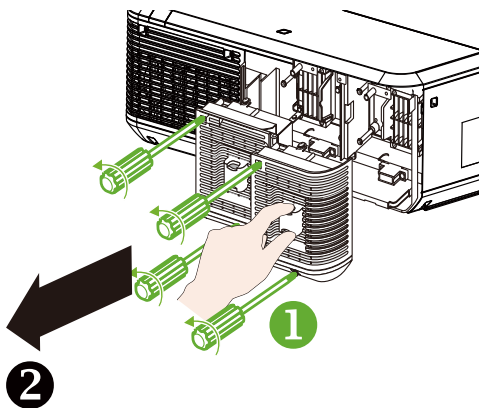

3. Remove the screw with the screwdriver ③ and take the old lamp out ④.

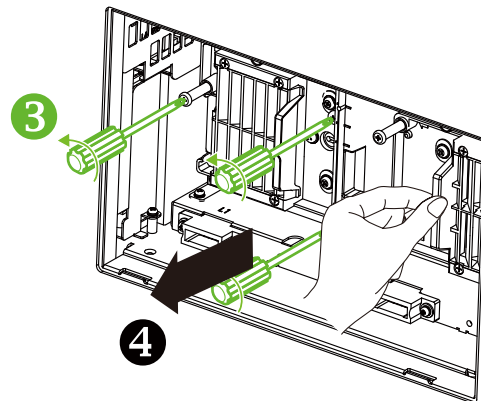

4. Insert the new lamp following the direction of the original lamp ⑤.

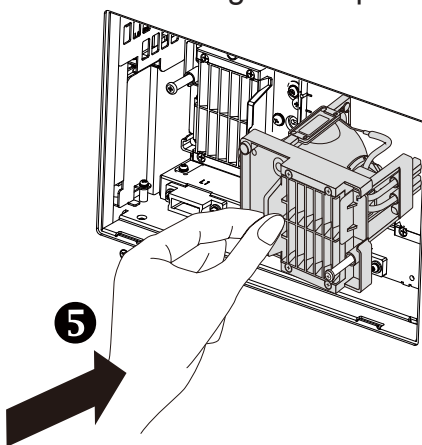

5. Tighten 3 screws on the lamp with the screwdriver ⑥, install the lamp cover and use the screwdriver to tighten the 2 screws on it ⑦.

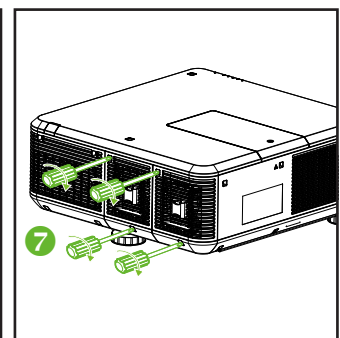
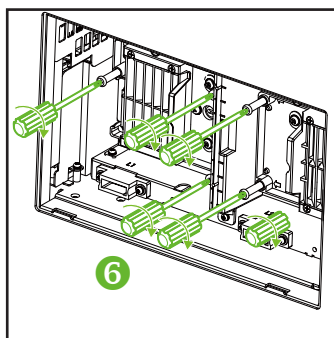

Note:

- After inserting the new lamp and tightening the 3 screws, please make sure the lamp is installed properly. Improper lamp installation may cause to system protection when projector is turned on. In this case, please double check if lamp is installed properly.

Installing or Removing the Projection lens

1. Remove the lens cover if the lens is not installed in the projector.
Pull the edge of the lens cover with one hand (①), so that the lens cover can be removed easily with the other hand (②).

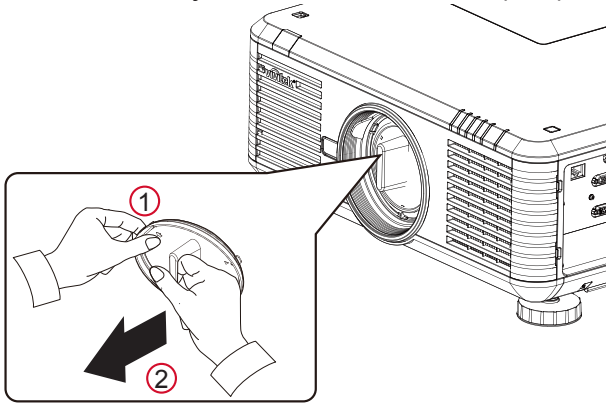

2. If the lens is installed in the projector, press the release button and support the lens with one hand. Turn the lens counterclockwise to loosen it and pull it from the holder.

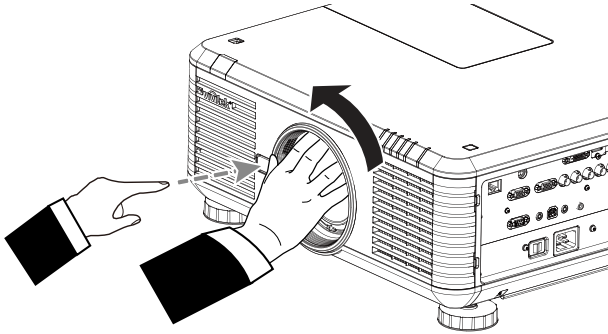

3. Align the "↑" symbol on the lens label with the "X" symbol on the top of the body (align to the center of the lens hole). Make sure the lens is pushed into the holder and turn it clockwise to the "Lock" position. When turning the lens, the "Click" sounds twice to indicate that the lens is completely fixed.

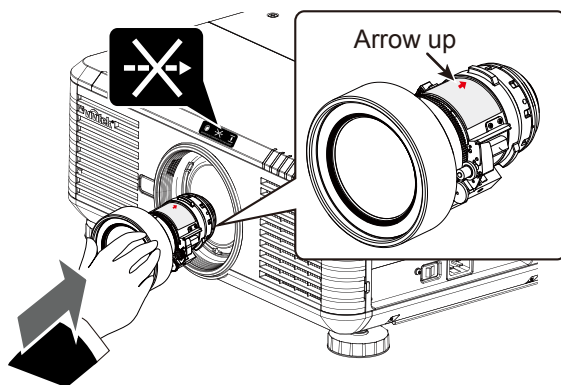

4. Try to pull the lens out of the holder gently to check if the lens is fixed.

Note:

- When removing the lens, make sure you press and hold the release button to loosen and unlock the lens from inside of the projector.
- The projector supports the lens memory function. Perform the memory function every time when you install the lens.

Replacing the filter

The dirtiness and replacement interval of the filter may vary depending on the dustiness of the environment. It is recommended to conduct regular check of the filter to achieve the best projector performance.

Note:

- Dirty filter may reduce the air flowing into the projector and the temperature in the projector may rise as a result. This may activate the protection mechanism or damage the components.
- Check, clean and replace the filter regularly.
- It is recommended to replace the filter every time when you replace the lamp.

Replace the filter on the left side of the projector

1. Pull the filter cover of the shield away from the front left side (❶) and remove the filter to the front(❷).

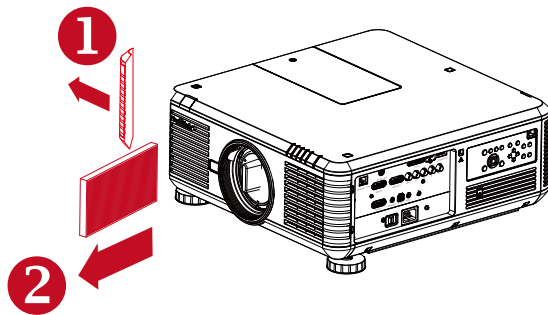

2. Install a new filter (❸) and place the shield on the front side to complete the replacement (❹).

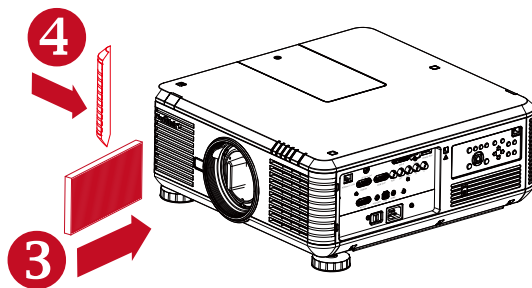

Replace the filter on the right side of the projector

1. Pull the filter cover of the shield away from the front right side (❶) and remove the filter to the right (❷).

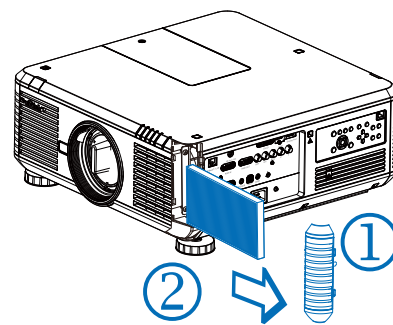

2. Install a new filter (❸) and place the shield on the front side to complete the replacement (❹).

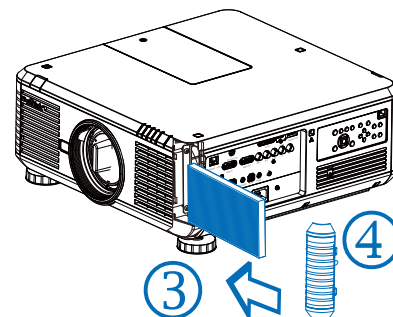

Changing the Color Wheel

1. The color wheel cover is located on the top cover of the projector. Loosen the screw of the color wheel cover with a screwdriver, and open the color wheel cover.

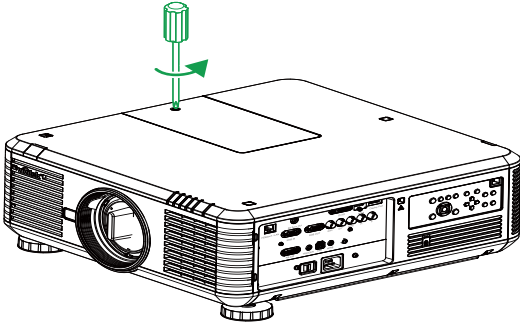

2. Loosen the 4 screws on the color wheel and remove the color wheel as shown in the figure below.

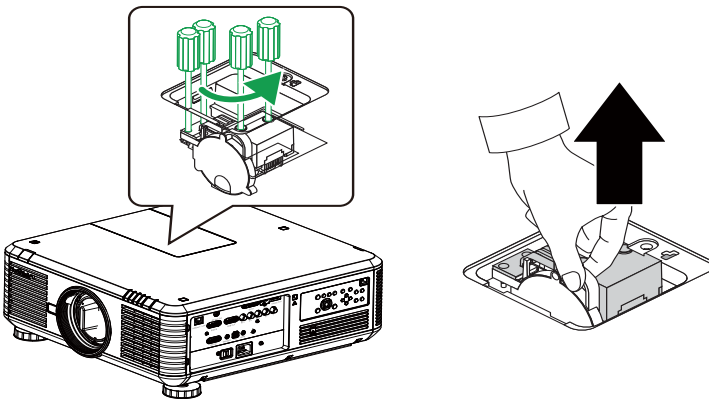

3. Put in the color wheel to be installed and tighten the 4 screws on the color wheel.

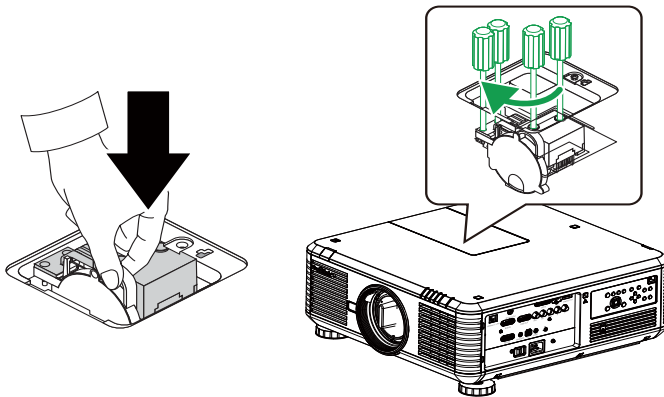

4. Place the lamp cover and use the screwdriver to tighten the screw on the color wheel cover.

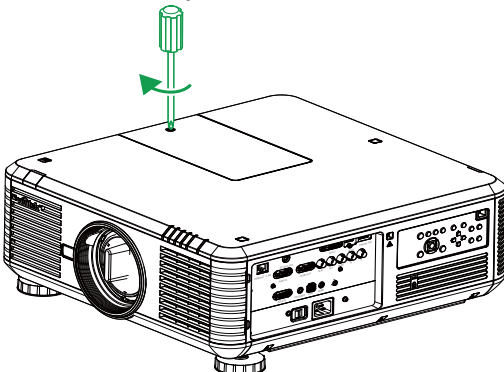

LED indicator status

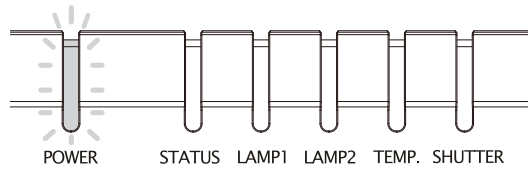

Power LED indicator

LED display		Projector status	Recommended actions
Off		AC power off	Use the AC power to turn on the projector
Flashing	Green	Ready to turn on the projector	Wait for the projector to display
	Orange	Projector cooling	Wait till the cooling is complete (~120 seconds)
Light up	Red	Standby Mode	To turn on the projector, press the ON button on the remote control or the Power button on the control panel.
	Green	Projector on	

Status LED indicator

LED display		Projector status	Recommended actions
Off		Normal	
Flashing	Red (1 times)	Shield breakdown	Make sure if the color wheel cover is properly mounted. If the failure can't be repaired, contact the local VIVITEK service center.
	Red (4 times)	Fan breakdown	Contact the local VIVITEK service center.
Light up	Red	System error	Contact the local VIVITEK service center.

Lamp 1/Lamp 2 LED indicator

LED display		Projector status	Recommended actions
Off		Lamp off	
Flashing	Green	Ready to light up	
	Red (6 times)	Lamp can't light up	Contact the local VIVITEK service center.
Light up	Red	Lamp service life ends	Contact the local VIVITEK service center.
	Green	Projector lamp operates normally.	

Temperature LED indicator

LED display		Projector status	Recommended actions
Off		Normal	
Flashing	Red	Abnormal temperature	Make sure the filter is not dirty, the intake or vent is not obstructed and the fan setting is correct. If the failure can't be repaired, contact the local VIVITEK service center.

Shutter LED indicator

LED display		Projector status	Recommended actions
Off		Shutter on	
Flashing	Green	Shutter off	

DU6871/DW6851/DX6831 specifications

Model	DU6871	DW6851	DX6831
Display type	DLP		
Typical brightness	7300 ANS lumens	7000 ANS lumens	8000 ANS lumens
Native resolution	WUXGA (1920x1200)	WXGA (1280x800)	XGA (1024x768)
Maximum resolution	WUXGA (1920x1200) @ 60Hz		
Contrast	3000:1		
Lamp life and type	2000/2500 hours (Standard/Eco mode), 400Wx2		
Throw Ratio*	1.73-2.27:1	1.81-2.38:1	1.79-2.35:1
Image Size*	40~500"	40~500"	40~500"
Projection Distance*	1.83-14.9m (6-49ft)	1.93-15.64m (6.3-51.31ft)	1.79-14.54m (5.87-47.07ft)
Projection Lens*	F=1.64-1.86 f=26-34mm		
Zoom Ratio*	1.3X		
Aspect Ratio	16:10 Normal 4:3 compatible with 16:9	16:10 Normal 4:3 compatible with 16:9	4:3 Normal 16:10 compatible with 16:9
Lens Shift*	0%~+50% (V); +/-10% (H)		
Keystone	V: +/-30°		
Sync	V: 48-120Hz H: 15-108kHz		
Edge blending	Yes (built-in)		
Video compatibility	SDTV (480i/576i), EDTV (480p/576p), HDTV (720p, 1080i/p)		
I/O Port	HDMI v1.4, DVI-D, DisplayPort, 3D Sync Out, HDBaseT (share with LAN control), RGB In, RGB Out, Component (YPbPr)/RGBHV, RS-232C, Screen Trigger, Wire (wired remote control), USB (repair port)		
Projection Method	Desktop projection, ceiling (front or rear)		
Size (W x D x W)	504x520x193mm (19.8"x20.5"x7.6") (excluding the protruding part)		
Weight (excluding the lens)	20kg (44.1lbs)		
Noise level	35dB/40dB (Dual-lamp Eco/Standard Mode)		
POWER	AC100-240V, 50/60Hz		
Power Consumption	Standby: 0.5W (No RJ-45, RS-232 activation)		
Accessories	AC power cord, VGA cord, remote control, lens cap, user manual CD		

* Standard Lens

Outline Dimensions

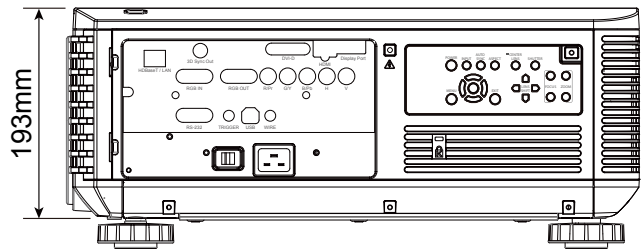
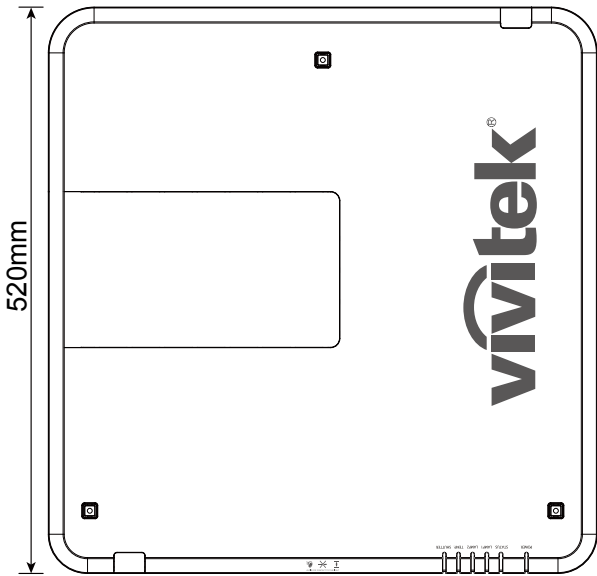
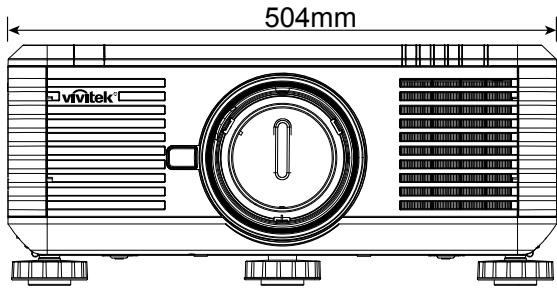

Supported Signal Input Timing

Computer

Signal type	Resolution	Frame rate	Component BNC		VGA		DVI-D	HDMI/HDBaseT		DisplayPort
			RGBHV	YUV	RGBHV	YUV		RGB	YUV	
PC	640x480	59.94	V		V		V	V		V
	640x480	75	V		V		V	V		V
	640x480	85	V		V		V	V		V
	800x600	75	V		V		V	V		V
	800x600	85.06	V		V		V	V		V
	848x480	47.95	V		V		V	V		V
	848x480	59.94	V		V		V	V		V
	1024x768	60	V		V		V	V		V
	1024x768	75.03	V		V		V	V		V
	1024x768	85.03	V		V		V	V		V
	1280x720	47.95	V		V		V	V		V
	1280x768	59.87	V		V		V	V		V
	1280x800	59.81	V		V		V	V		V
	1280x960	60	V		V		V	V		V
	1280x1024	60.02	V		V		V	V		V
	1280x1024	75.02	V		V		V	V		V
	1280x1024	85.02	V		V		V	V		V
	1366x768	59.79	V		V		V	V		V
	1440x900	59.887	V		V		V	V		V
	1600x1200	60	V		V		V	V		V
1920x1080	47.95	V		V		V	V		V	
1680x1050	59.94	V		V		V	V		V	
1920X1200 (Reduce Blanking)	60	V		V		V	V		V	
1400X1050	60	V		V		V	V		V	
Apple Mac	640x480	66.59	V		V		V	V		V
	832x624	74.54	V		V		V	V		V
	1152x870	75								V
SDTV	1440x480i	60						V	V	V
	1440x576i	50						V	V	V
EDTV	480p	59.94	V	V	V	V	V	V	V	V
	576p	50	V	V	V	V	V	V	V	V
	1080i	50	V	V	V	V	V	V	V	V
	1080i	59.94	V	V	V	V	V	V	V	V
	1080i	60	V	V	V	V	V	V	V	V
	720p	50	V	V	V	V	V	V	V	V
	720p	59.94	V	V	V	V	V	V	V	V
	720p	60	V	V	V	V	V	V	V	V
	1080p	23.98	V	V	V	V	V	V	V	V
	1080p	24	V	V	V	V	V	V	V	V
	1080p	25	V	V	V	V	V	V	V	V
	1080p	29.97	V	V	V	V	V	V	V	V
	1080p	30	V	V	V	V	V	V	V	V
	1080p	50	V	V	V	V	V	V	V	V
	1080p	59.94	V	V	V	V	V	V	V	V
1080p	60	V	V	V	V	V	V	V	V	

3D Signal Input Mode

Signal type	Resolution	Frame rate	Frame Packing	Side by Side	Top/Bottom	Farm Sequential
PC	640x480	59.94				V
	848x480	47.95				V
	848x480	59.94				V
	1024x768	60				V
	1280x720	47.95				V
	1280x768	59.87				V
	1280x800	59.81				V
	1280x960	60				V
	1280x1024	60.02				V
	1366x768	59.79				V
	1440x900	59.887				V
	1600x1200	60				V
	1920x1080	47.95				V
	1680x1050	59.94				V
	1920X1200 (Reduce Blanking)	60				V
	1400X1050	60				V
EDTV	1080i	59.94		V		
	1080i	60		V		
	720p	50	V		V	V
	720p	59.94	V		V	V
	720p	60	V		V	V
	1080p	23.98	V		V	
	1080p	24	V		V	
	1080p	50				V
	1080p	59.94				V
	1080p	60				V

DU6871/DW6851/DX6831 lens series

7 types of optional electric lenses are available for the projector. Contact the authorized dealer of Vivitek for details.

Part Number	Lens Name	F Number	Focal Length	Zoom Ratio	Screen Size	Throw Ratio		
						DU6871	DW6851	DX6831
D88-UWZ01	Ultra Wide Zoom	1.96-2.3	11.3-14.1mm	1.25:1	40"-500"	0.75-0.93:1	0.78-0.99:1	0.77-0.97:1
D88-WF18501	Wide Fix	1.85	11.6mm	---	40"-500"	0.76:1	0.8:1	0.79:1
D88-WZ01	Wide Zoom	1.85-2.5	18.7-26.5mm	1.41:1	40"-500"	1.25-1.79:1	1.31-1.87:1	1.3-1.85:1
D88-ST001	Standard Lens	1.7-1.9	26-34mm	1.3:1	40"-500"	1.73-2.27:1	1.81-2.38:1	1.79-2.35:1
D88-SMLZ01	Semi Long Zoom	1.86-2.48	32.9-54.2mm	1.65:1	40"-500"	2.22-3.67:1	2.33-3.86:1	2.3-3.81:1
D88-LOZ101	Long Zoom 1	1.85-2.41	52.8-79.1mm	1.5:1	40"-500"	3.58-5.38:1	3.76-5.64:1	3.71-5.57:1
D88-LOZ201	Long Zoom 2	1.85-2.48	78.5-121.9mm	1.55:1	40"-500"	5.31-8.26:1	5.56-8.67:1	5.5-8.56:1

- Above lenses can support to vertical shift 0-50%, horizontal shift $\pm 10\%$ except of D88-WF18501.
- D88-WF18501 is a fixed lens, the vertical and horizontal shift range is 0%, the corners of the projected image may appear shadows or distortion if lens is shifted horizontally or vertically.
- Projector lens supports Lens memory function, please perform Center Lens function after changing the lens. If you do not perform this function, the projector will not be able to get an accurate lens parameters, some of lens control features may not be accurate action.

About the VIVITEK support

If you have any problems with the setting or operation of the projector, refer to Chapter "Status LED indicator" on page 48. If you cannot find solutions from this user guideline, please contact us using the contact information below.

North America

Vivitek Service Center
15700 Don Julian Road, Suite B
City of Industry, CA. 91745
U.S.A

Tel: 855-885-2378 (Toll-Free)
Email: T.services1@vivitekcorp.com
URL: www.vivitekusa.com

Europe, Middle East and Africa

Vivitek Service & Support
Zandsteen 15
2132 MZ Hoofddorp
The Netherlands

Tel: +31 20 655 0960
Email: support@vivitek.eu
URL: www.vivitek.eu

China

Vivitek Service Center
上海浦东世纪大道 1090 号斯米克大厦 18 层 1802 室, 201209

Tel: 400-888-3526 (Toll-Free)
Tel: 021-58360088-142 (Direct)
Email: service@vivitek.com.cn
URL: www.vivitek.com.cn

Asia and Taiwan

VIVITEK after-sales service
Vivitek Corporation, Co., Ltd.
4F., No.186, Ruiguang Rd., Neihu Dist., Taipei City 11491

TEL: 86-28-797-2088
FAX: 86-26-600-2358
E-mail: kenny.chang@vivitek.com.tw
URL: www.vivitek.com.tw